A blue metal barrier with the Parklio logo and name on its top arch, set against a clear blue sky. The barrier is mounted on a base with four wheels.

Automatic barrier with smartphone control feature

Automatic closing feature

Operating autonomy up to 1 year (rechargeable li-ion batteries)

Solar panel for extended autonomy

Manual control possibility

3 available models (Zeus X, AC-POWERED and CUSTOM MODEL)

Parklio™ Barrier

USER MANUAL



Dear Customers,

Thank you for the confidence you have shown us by purchasing our parking barrier. We hope that all your expectations of this product will be fulfilled. Parklio Smart Parking Barrier is manufactured using the latest technologies and has undergone rigorous quality control procedures. The User Guide will help you use your product quickly and safely. Information contained in this manual is subject to change without notice.

Attention!

- Please read the user manual and technical sheet before installing and using the Parklio smart parking barrier.
- Always follow the safety instructions.
- Keep this user manual at hand for future reference.

TABLE OF CONTENTS

Parking barrier components.....	5
Barrier components overview.....	5
Barrier base.....	6
Control unit.....	7
Battery pack.....	7
Safety pin.....	9
Power supply (constant power supply option).....	10
Parking Barrier features.....	12
Solar panel.....	12
Vehicle detection.....	12
Auto-close.....	12
Technical characteristics.....	13
Safety warnings.....	15
Installation.....	17
Packaging contents.....	17
Unpacking the barrier.....	17
Inserting safety pin and testing the barrier.....	18
Positioning the barrier for installation.....	19
Mounting the base.....	19
Installing the power supply (only for constant power supply model).....	22
Inserting the battery.....	25
Connecting the power.....	25
Final steps.....	25

TABLE OF CONTENTS

Controlling the barrier	26
Installing the application.....	26
Register and login.....	27
Adding the barrier to your account.....	28
Connecting to the barrier.....	29
Opening and closing the barrier.....	30
Barrier settings and information.....	31
Keyfob.....	37
Barrier key reset.....	39
Manual barrier control	40
Cleaning and maintenance	41
Cleaning the laser sensor.....	41
Cleaning the inside of the barrier cover.....	41
Cleaning the barrier exterior.....	42
Replacing the safety pin.....	42
Disposal of the device	43
FAQ	44

1. Parking barrier components

This Section will describe all the components a barrier is made of:

■ 1.1. Barrier components overview

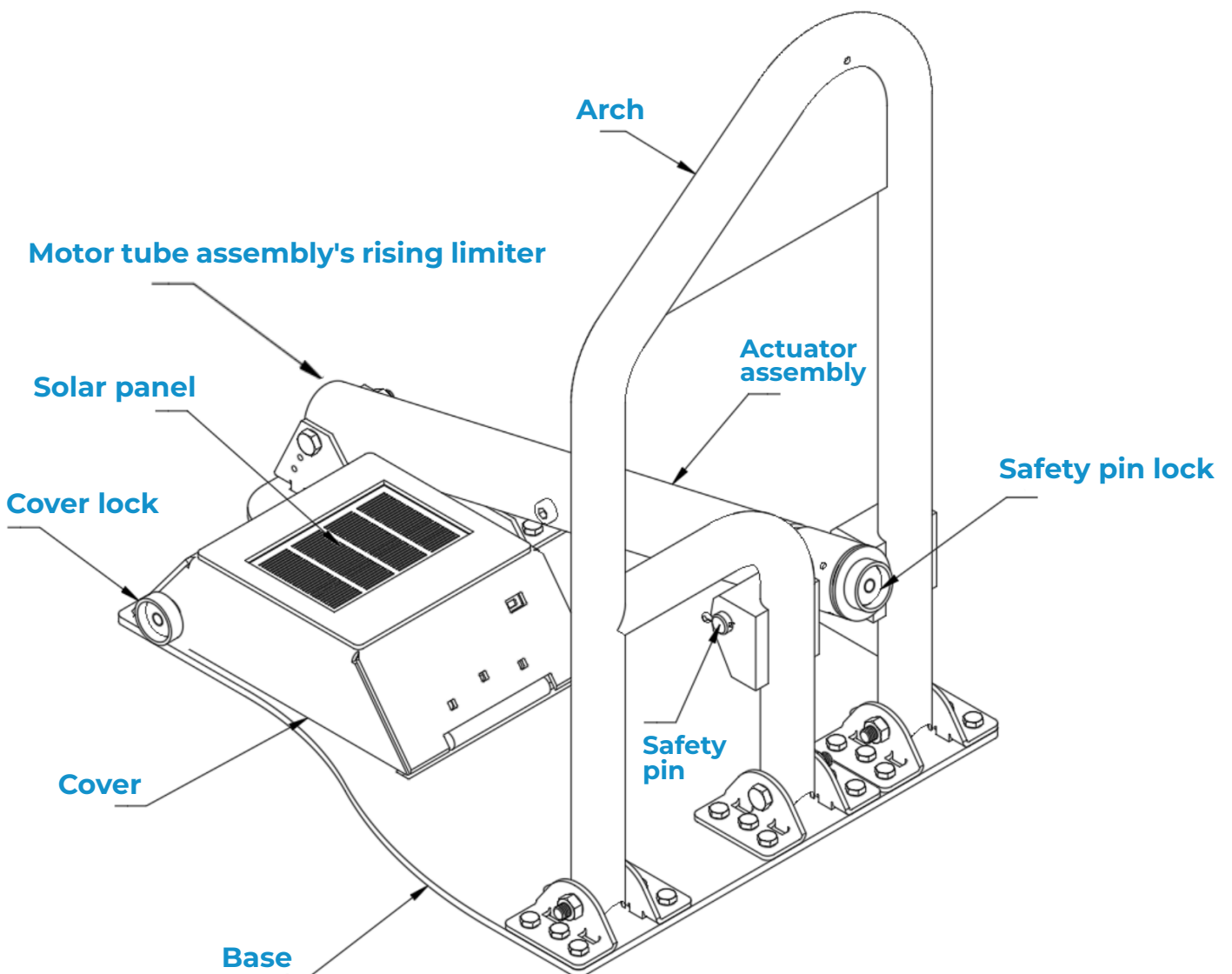

Parking barrier parts

■ 1.2. Barrier base

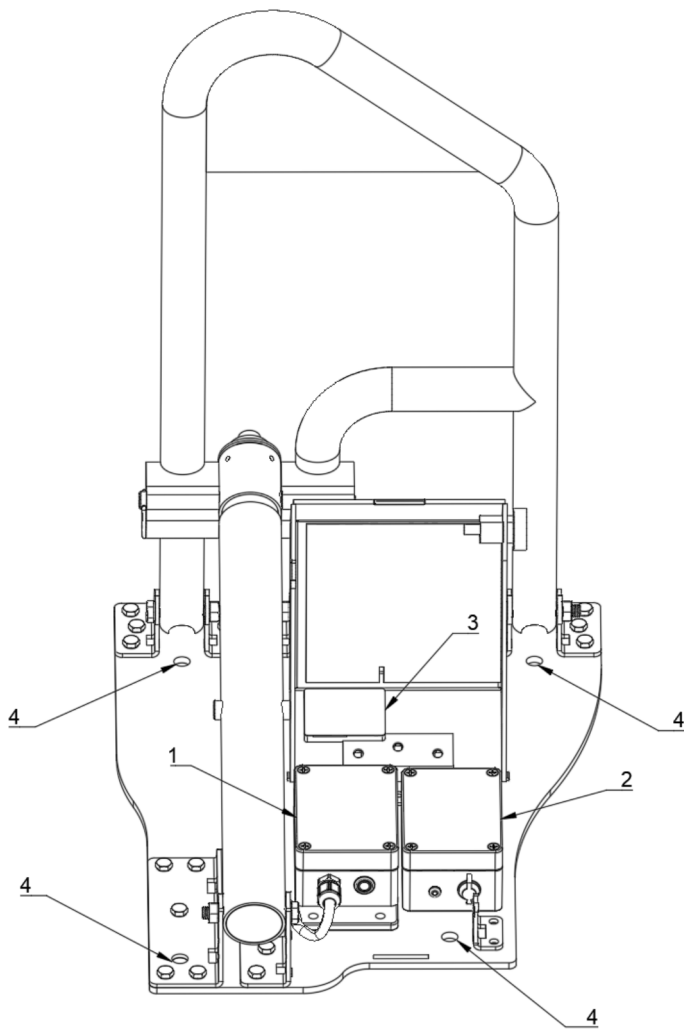

Battery powered barrier back view

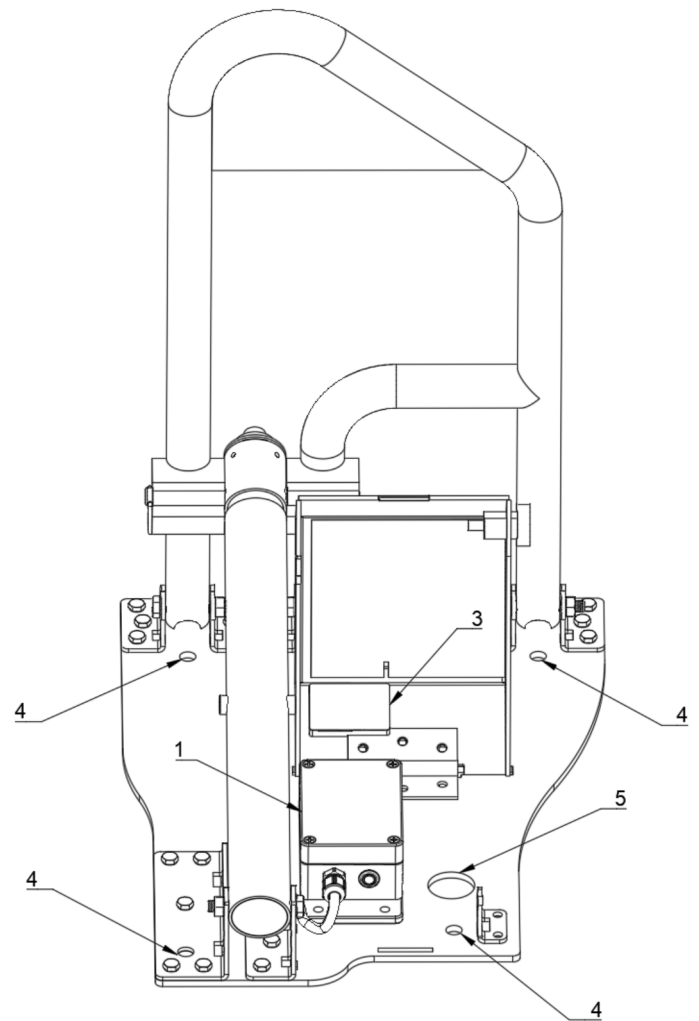

Constant supply model

- 1. Control Unit Electronics
- 2. Battery Pack
- 3. Laser Sensor Assembly
- 4. Mounting Holes
- 5. Cable Hole

■ 1.2.1 Control unit

The control unit contains the BLE radio and is responsible for controlling the barrier. It connects to the actuator, laser sensor and battery.

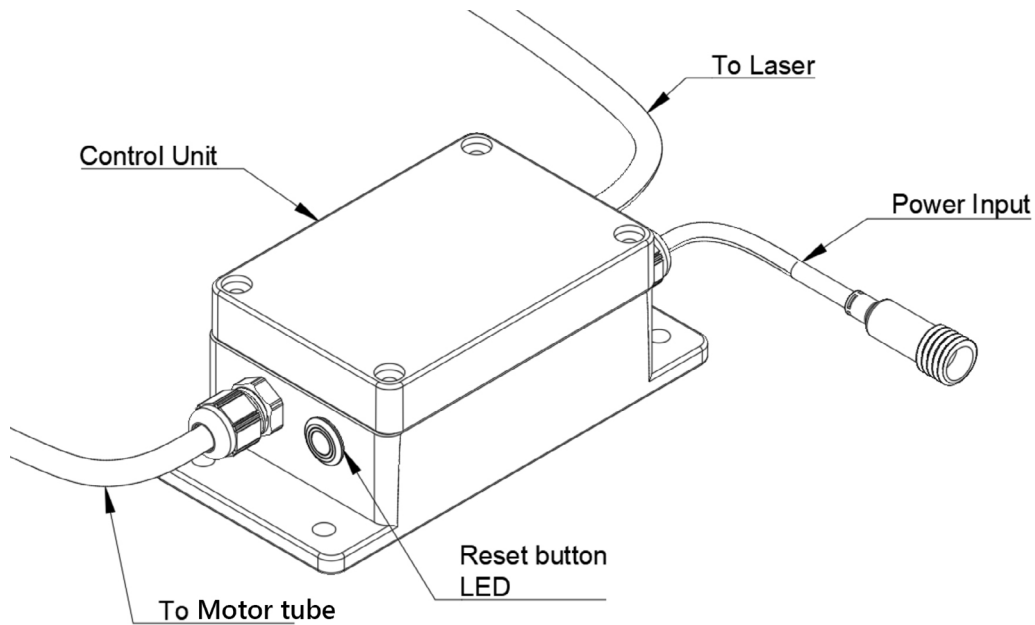

■ 1.2.2. Battery pack

Parklio™ Battery Pack is a portable power supply for use with the Parklio Smart Parking Barrier. Parklio barriers support the use of *Parklio Battery Packs* and *Parklio Double Battery Packs*.

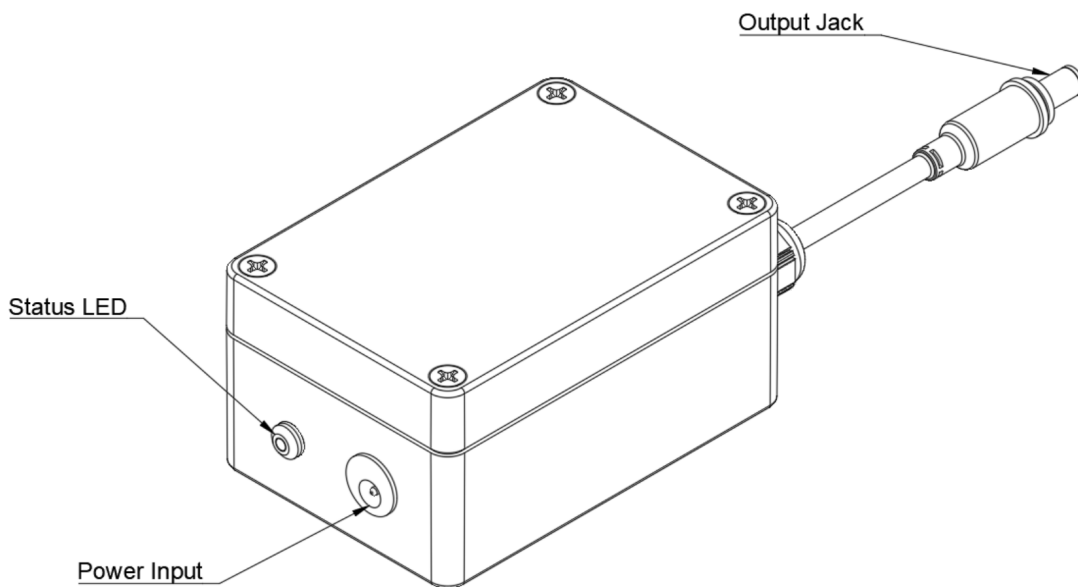

LED State	Description
Off	The battery pack is charged or the battery pack is not connected to a charger.
On	The battery pack is connected to a charger and charging.
Blinking	There is an error during charging. Stop charging immediately.

Please refer to the Parklio Smart parking barrier complete technical sheet for additional information.

To charge the battery pack first remove the plug from the charging input port and connect the provided charger to the battery pack charger input. The LED should turn green indicating that the battery pack is charging. Only use the provided charger with the battery pack.



Charging the battery in temperatures below 0°C must be avoided as it may potentially damage the battery and reduce its lifespan.

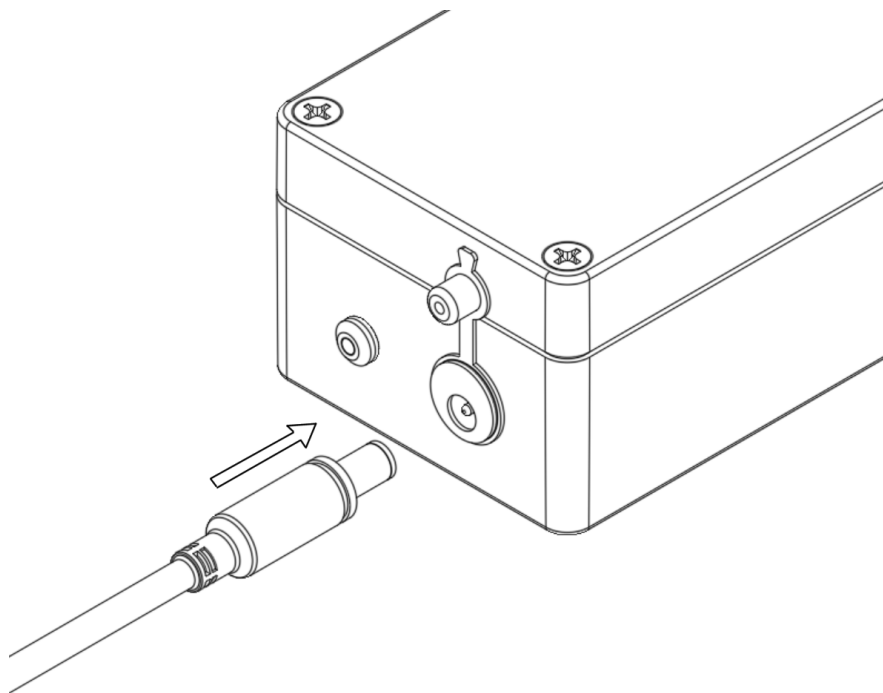

The charging cycle is complete after the LED turns off.

After charging please make sure to close the charger input plug.

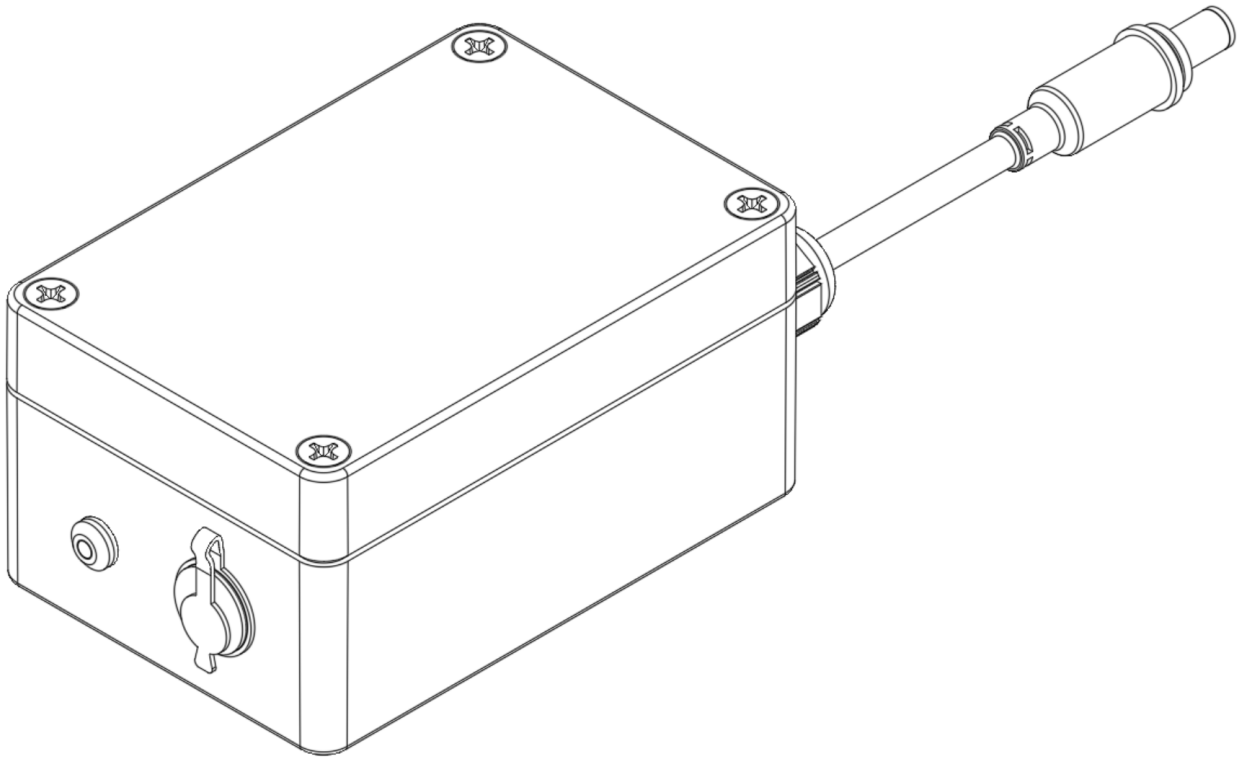

■ 1.3. Safety pin

The barrier uses a safety pin to connect the actuator to the barrier arm. The pin allows manual operation, by removing the pin and lowering the barrier, and acts as a safety device to protect the barrier from excessive force. The pin is designed to break into three pieces in case of excessive frontal force to the arm and may be replaced by a new one.

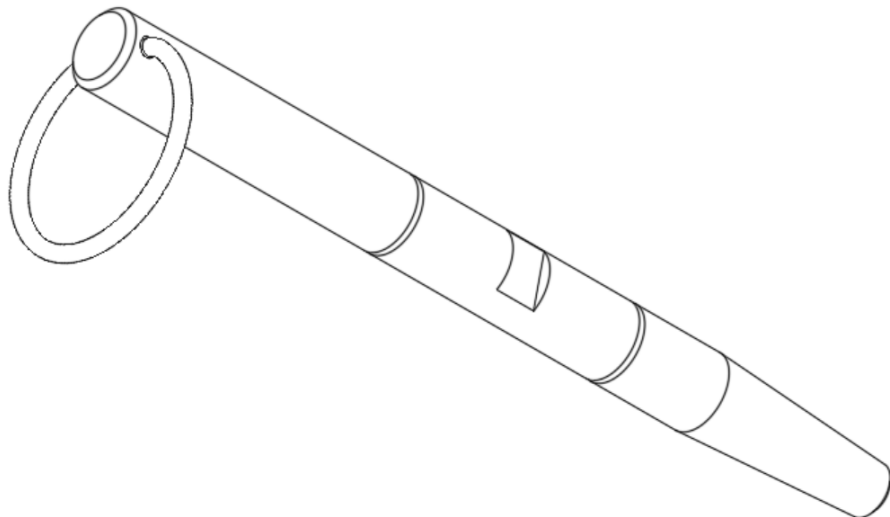

■ 1.4. Power supply (constant power supply option)

The constant power supply option barrier comes with an external AC/DC power supply. The supply is powered from the electric line and its output is fed to the barrier. The provided supply is adjustable from 10.2 V to 13.4 V, it comes preset to 10.2V. The voltage to the barrier should never exceed 11V.

Input voltage:	85 Vac to 264 Vac
Input voltage frequency:	47 Hz to 63 Hz
Efficiency:	83 %
Input current:	1.2 A (115 Vac) 0.8A (230 Vac)
Inrush current:	30A (115 Vac) 60A (230 Vac)
Output voltage:	10.8 Vdc - 13.8 Vdc
Continuous output current:	4.5 A
Rated power:	54 W
No load power:	0.3 W
Output ripple voltage:	120 mVpp
Operational temperature:	-30 °C to 70 °C
Operational humidity:	20 % to 90 %, non-condensing
Operational altitude:	2000 m
Protection:	Over voltage Current limiting Overload Short circuit Overcurrent
Dimensions:	52.5 mm x 90 mm x 54.5 mm
Mounting:	DIN rail

External AC/DC Power supply specifications

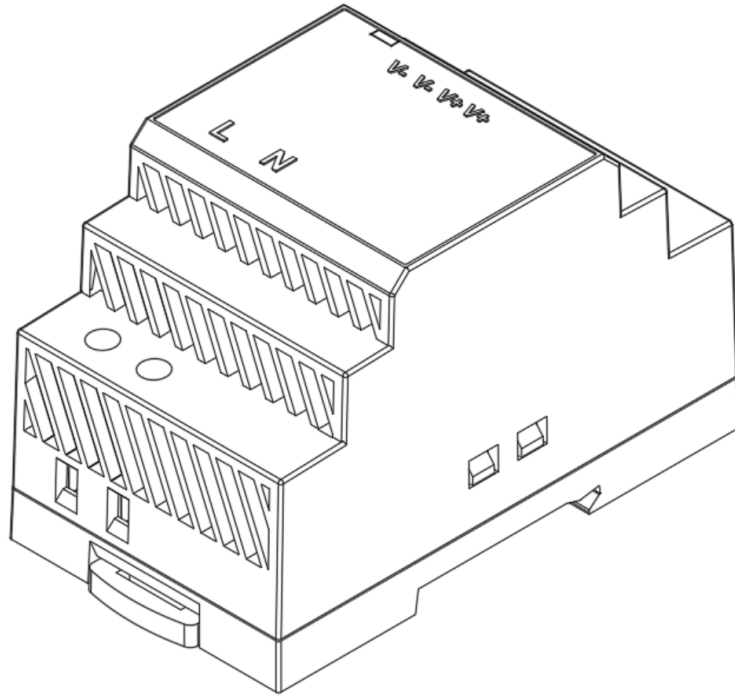

2. Parking barrier features

This section will provide a description of the parking barrier features.

■ 2.1. Solar panel

The Parklio Smart Parking Barrier is equipped with a small size, high efficiency, solar panel. The solar panel enables extended autonomy of the barrier by gradually charging the barrier's battery when there is enough sunlight.

■ 2.2. Vehicle detection

The Parklio Smart Parking Barrier is equipped with software and a set of sensors designed to detect vehicle presence over the barrier. The barrier will not allow the user to open it while there is a vehicle on top.

■ 2.3. Auto-close

The auto-close feature enables automatic barrier closing when the vehicle parked over the barrier departs. A set of sensors on the barrier detects the presence of a vehicle. The auto-close function is activated once the car remains parked over the open barrier for more than 60 seconds, however the barrier won't autoclose until the vehicle exits the parking area in a continuous movement and passes to a distance of about 3-4 meters from the barrier. The barrier waits a defined time interval before automatically closing. The interval may be customized in the settings so you set up the preferred closing time.

3. Technical characteristics

For a full list of technical characteristics please consult the technical sheet. Due to improvements of the product quality, technical specifications may change without previous notification. The figures in this manual are schematic and may not match the product completely. The values stated on the product labels or in the accompanying documentation have been obtained in laboratory conditions in accordance with the relevant standards. Depending on working conditions and environmental conditions, these values may be different.

Dimensions (barrier opened):	918 mm x 331 mm x 70 mm
Dimensions (barrier closed):	453 mm x 331 mm x 517 mm
Weight:	15.2 kg
Working temperature:	-20 °C to 60 °C
Working humidity:	5 % to 95 % RH, non-condensing
Operating altitude:	2000 m
Ingress protection:	IP65
Nominal travel time:	<5 s
Power supply:	Parklio battery pack Parklio double battery pack AC/DC external low voltage power supply (constant supply)
Operating voltage:	6 Vdc – 11 Vdc
Current consumption (operation):	2 A continuous, 8 A peak current
Current consumption (standby):	100 uA average standby current
Wireless connectivity:	Bluetooth LE
Over-The-Air upgrades:	Yes
Antenna interface:	Internal 2.4 GHz antenna
Sensors:	One magnetic sensor and one Class 1 laser sensor for detecting vehicle presence
Protection and coatings:	Cold dip galvanized and lacquered, powder coated Stainless steel

Parklio Smart Parking Barrier technical data

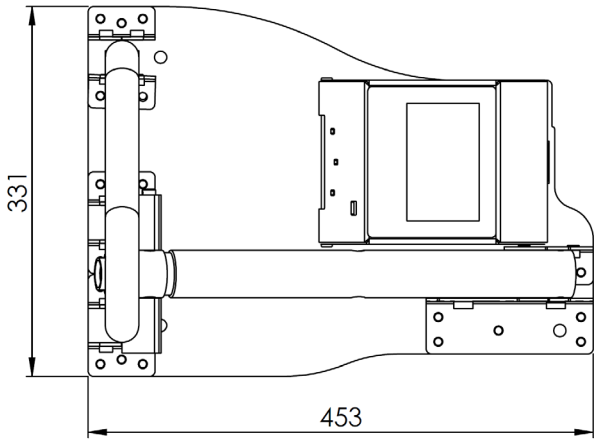

Barrier Raised - Top View

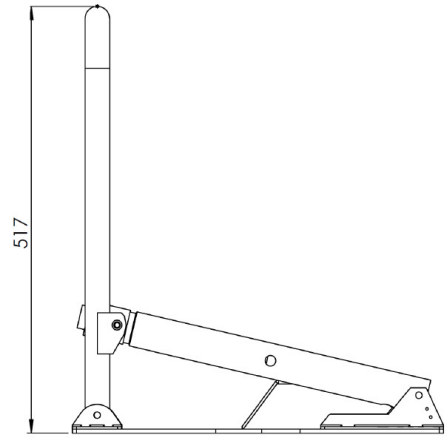

Barrier Raised - Side View

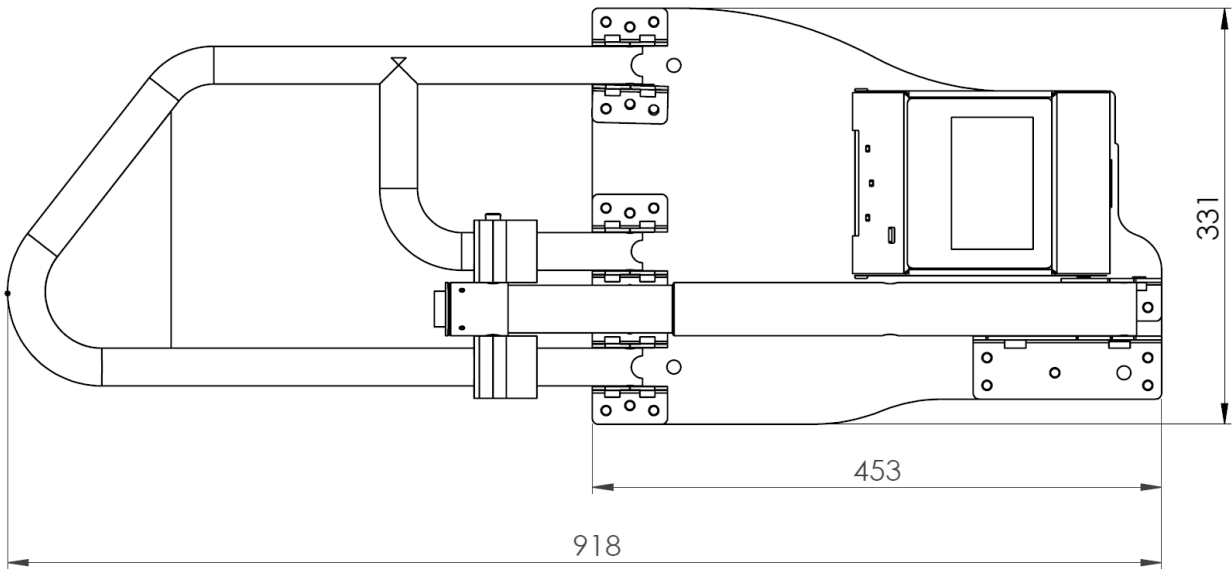

Barrier Lowered - Top View

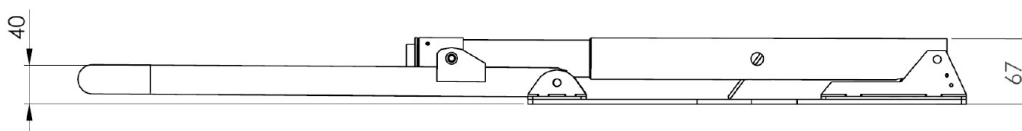

Barrier Lowered - Side View

Overall barrier dimensions

4. Safety warnings

This section contains safety instructions that will help to protect you from risk of injury or property damage. Failure to follow these instructions will invalidate all warranties.

- Do not use the barrier, if you have not read and understood the operating instructions before.
- Before first use of the barrier, make sure that all the parts listed in these instructions are inside of the original packaging.
- Only plugs, batteries, chargers, spare parts and power supplies, supplied by the manufacturer of the barrier should be used. Use of non-manufacturer provide parts may affect the loss of warranty.
- Ignoring usage instructions, improper installation and use of the barrier may result in damage to the barrier or injuries to the user. Instructions should always be at hand.
- Never expose the inner workings to water.
- The device must be exclusively installed on a hard, flat concrete floor.
- The device and external supply must be disconnected from power supply during installation, maintenance, cleaning and repairs.
- Leave the barrier repairs to a specialist. Improper repairs may lead to an accident or a malfunction in the unit.
- Please charge the battery to full capacity before first use.
- Only charge the battery pack with the provided power adapter.
- The battery pack is fragile, please handle it with care. Do not expose the battery to direct heat.
- The battery pack is intended to be used only with Parklio products, use with other products is not recommended. Parklio is not responsible for any damage caused to the equipment or the battery pack when used incorrectly.
- Make sure to close the power input plug of the battery pack before use to seal the port from water ingress.
- The warranty does not cover consumable parts of the device, color fading and chipping, increased noise as a result of aging of the device and other aesthetic effects that do not affect its functionality or safety. Never use chemical solvents on the product as it may cause an explosion.
- Strictly follow the instructions for proper installation and connection to the electrical network.
- The installer must provide a device (e.g. magnetothermic switch) ensuring the omnipolar sectioning of the equipment from the power supply. The standards require a separation of the contacts of at least 3 mm in each pole (EN 60335-1).
- Installation requires mechanical and electrical skills, therefore it shall be carried out by qualified personnel only, who can issue the Compliance Certificate concerning the whole installation.
- The upstream electric system shall comply with the laws and rules in force.
- Do not install the product in explosive environments and atmospheres, the presence of inflammable gases or fumes is a serious safety hazard.

PARKLIO (PARKLIO D.O.O.) HAS THE RIGHT TO MODIFY THE DEVICE WITHOUT PREVIOUS NOTICE. PARKLIO (PARKLIO D.O.O.) DECLINES ANY RESPONSIBILITY FOR DAMAGE OR INJURY TO PEOPLE OR THINGS CAUSED BY IMPROPER USE OR WRONG INSTALLATION.

THE APPLIANCE HAS BEEN ESTABLISHED ACCORDING TO ALL VALUENT SAFETY CRITERIA AND STANDARDS. HOWEVER, WE RECOMMEND THAT WITHOUT THE NEEDED HELP AND SUPERVISION, CHILDREN, A PERSON WITH DISABLED PHYSICAL, MOTOR, OR PERSONAL EQUALITY AND RELATED PEOPLE WITHOUT PREVIOUS EXPERIENCE OR KNOWLEDGE DO NOT USE THE BARRIER. EXCEPTION IS THE DEVICE USAGE UNDER ADEQUATE SUPERVISION IF THEY HAVE RECEIVED SAFETY INSTRUCTIONS AND TRAINING, OR IF THEY ARE INFORMED ABOUT THE DANGER CAUSED BY IMPROPER USAGE. THE SAME RECOMMENDATION IS FOR JUVENILES AND THEIR USAGE OF THE DEVICE.

DO NOT ALLOW CHILDREN TO PLAY WITH THE DEVICE. DO NOT LET CHILDREN CLEAN THE DEVICE, USE IT, NOR MAINTAIN IT, WITHOUT ADEQUATE SUPERVISION.

5. Installation

This section will provide description of the barrier packing contents and detailed instructions on how to install the barrier.

■ 5.1. Packaging contents

Please check that all necessary parts are delivered with the package. The packaging should contain the following:

1. 1 x Parklio barrier
2. 1 x Parklio battery pack **(BATTERY POWERED OPTION)**
3. 1 x Power adapter for charging the battery **(BATTERY POWERED OPTION)**
4. 1 x AC/DC Power supply **(CONSTANT SUPPLY OPTION)**
5. 4 x Anchor screws
6. 2 x Keys
7. 1 x Safety pin
8. 1 x User manual

If any of the parts are incorrect, missing, or damaged, contact your Parklio™ dealer. Keep the carton, including the original packing materials, in case you need to return the product for repair.

■ 5.2. Unpacking the barrier

The barrier is delivered sealed and folded.

After opening the package, remove the smaller box and lift the barrier arm to remove the safety pin. Pull the barrier out of the box by gripping it by the base with both hands. To prevent damage, never remove the barrier from the box by pulling on the barrier arm. Place it on a flat concrete floor and unfold the barrier arm to the ground.

Please inspect the barrier for damage and test it before securing it to the ground.



The motor tube assembly has a rising limiter that prevents you from raising the actuator too high when inserting a safety pin - causing damage to the wiring. Don't force raise it as it will cause the rising limiter to break and the wiring problem that will prevent your barrier from functioning normally.

■ 5.3. Inserting safety pin and testing the barrier

To test the barrier, insert the safety pin that connects the barrier arch to the motor tube.

STEP 1. Unlock the motor tube by inserting the key and rotating it. The lock should pop out.

STEP 2. Raise the motor tube to the same level as the arch and insert the safety pin through both the arch and the tube.

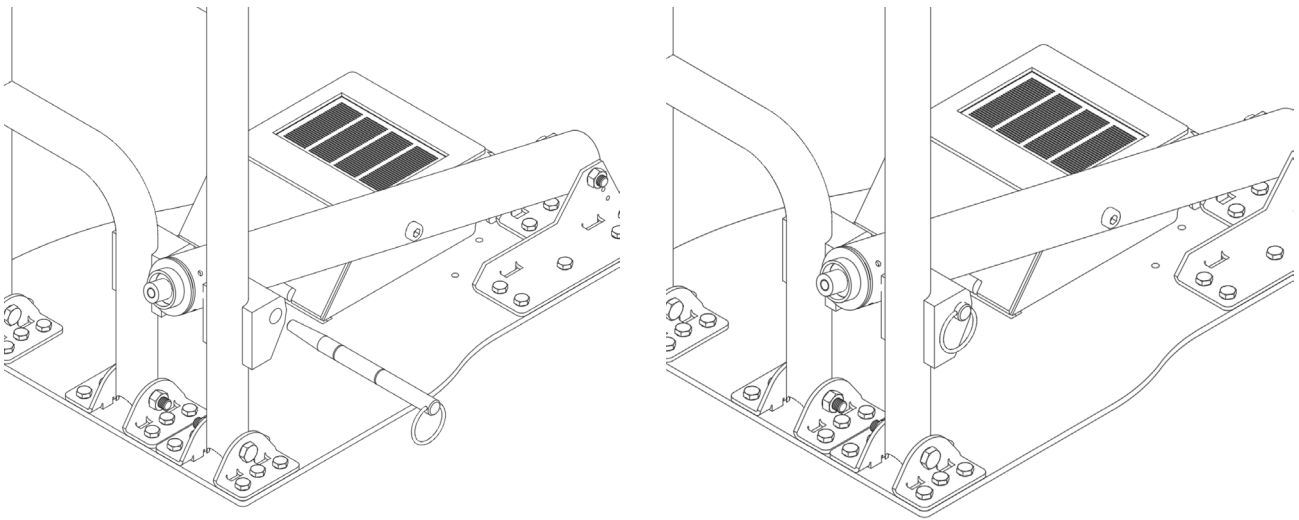

STEP 3. Adjust the safety pin so it is positioned in a way that the notch in the safety pin is pointing at the lock. Fully insert the safety pin and slightly rotate it while depressing the lock. Close the lock with the cover.

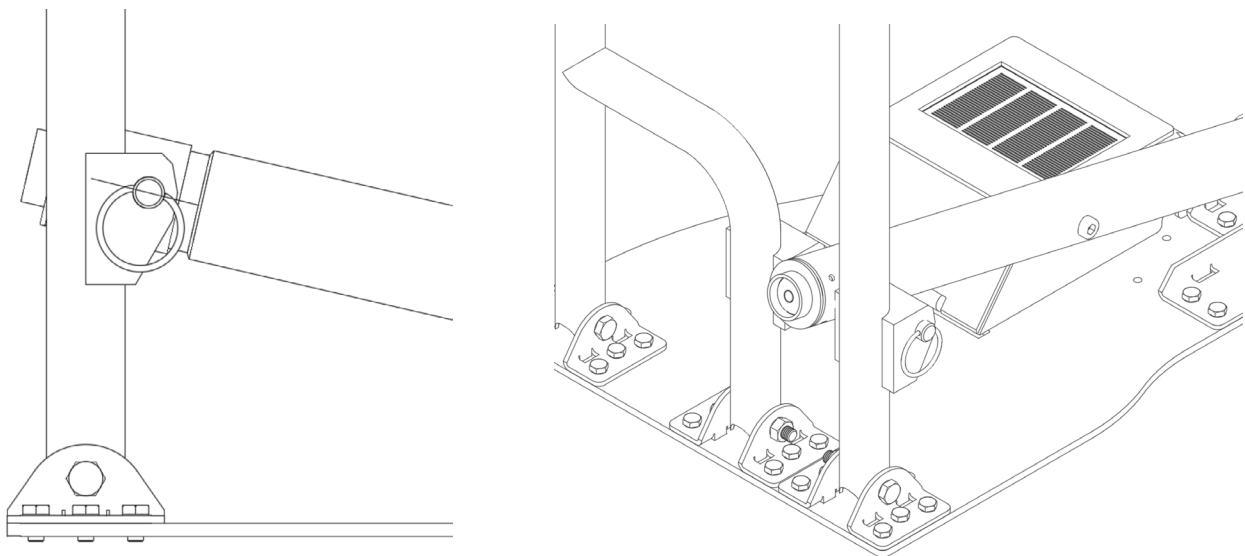

After that install Parklio Connect app as described in section 6 of the user manual and test the barrier by extending it and lowering it.

■ 5.4. Positioning the barrier for installation

The illustration below is only a proposal for setting the barrier. We do not condition users setup but we recommend for full functionality of the barrier to position the barrier so that the parked vehicle covers the whole barrier when the barrier is in the open position.

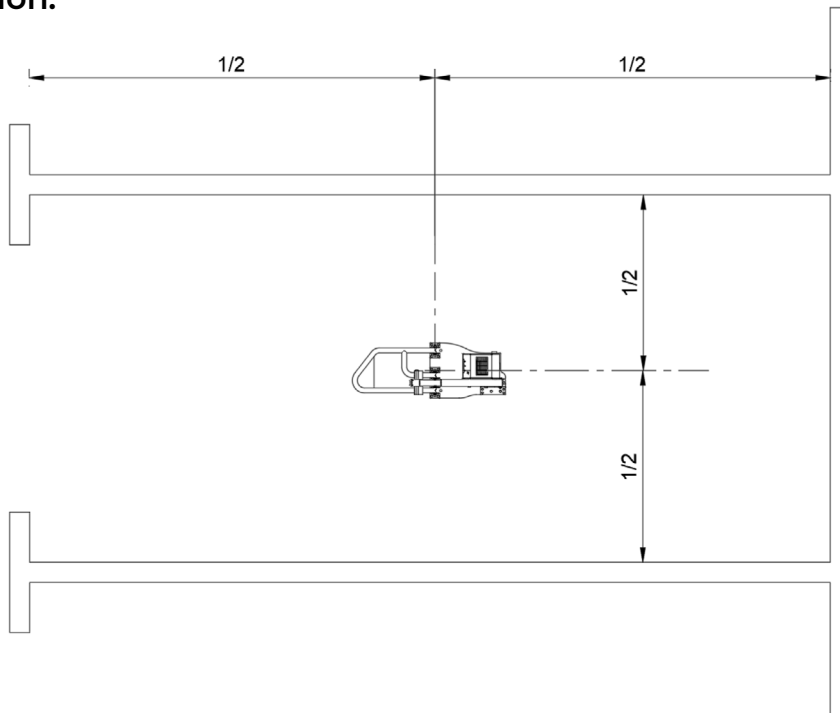

■ 5.5. Mounting the base

Required tools and equipment:

- Drill
- Hammer
- 10 mm masonry carbide drill bit
- 13 mm socket wrench

Additional tools for constant power supply option:

- PH1 insulated screwdriver
- PH0 or 2 mm flat insulated screwdriver



Do not attempt to secure the Parklio barrier in any other way than described in this user manual because any different kind of securing the barrier (ex. like fixing it to the ground with concrete) can cause problems for the moving parts of the barrier. The Parklio barrier must be installed on a solid surface by placing anchor screws as shown in the user manual.

The below steps only apply if you are installing the barrier on a hard concrete surface. If installing the barrier on different surfaces please advise with the manufacturer what are the best practices and tools for installation.

STEP 1. Position the barrier in accordance with the above instructions.

STEP 2. Mark the four mounting holes.

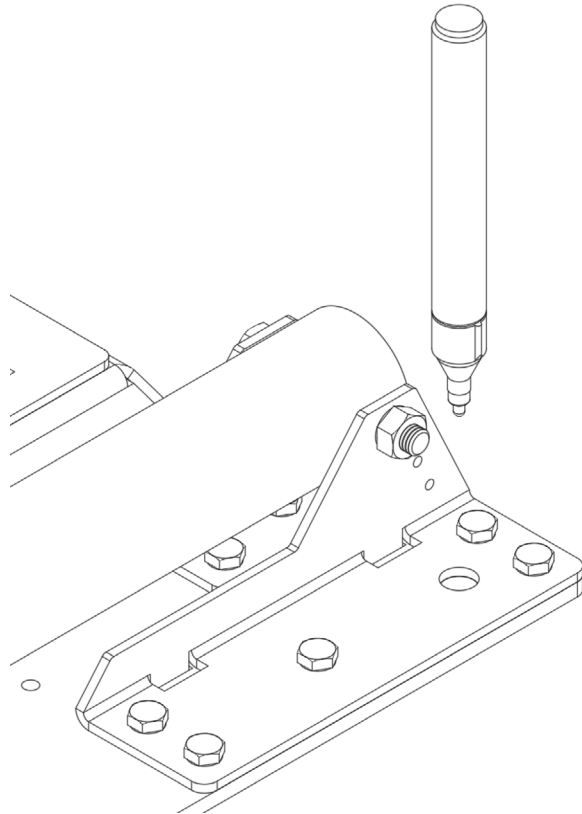

STEP 3. Drill the holes for the anchor screws. Clear the holes of any dust.

Tip: You can skip marking the holes and use the barrier base as the template. Make sure that the barrier base doesn't move while you drill so you don't damage it.

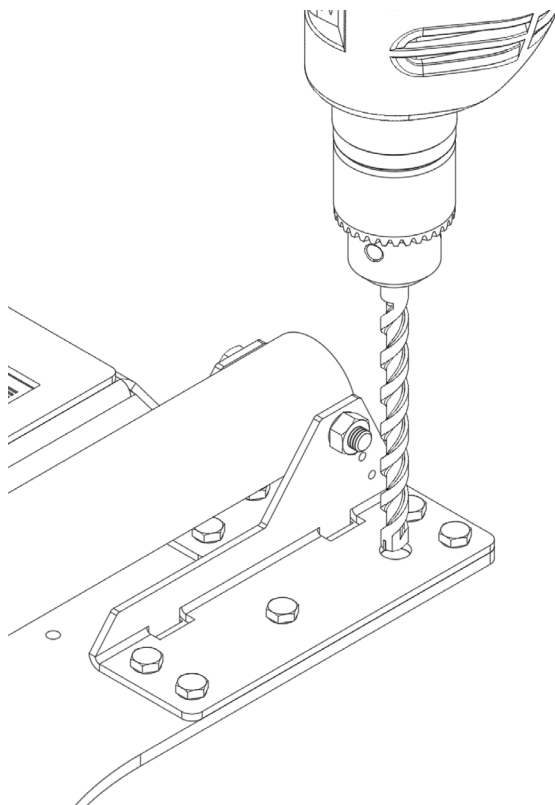

STEP 4. Place the barrier and align the mounting holes with the drilled spots. Insert the anchor screws by tapping them with a mallet.

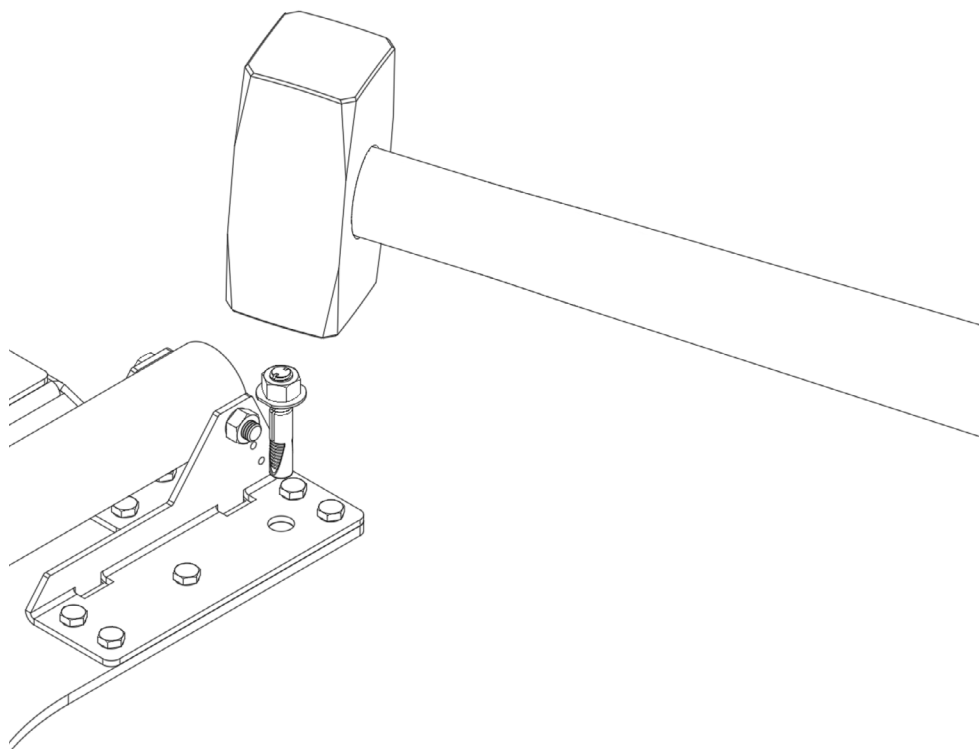

STEP 5. Tighten the anchor screws with a socket wrench.

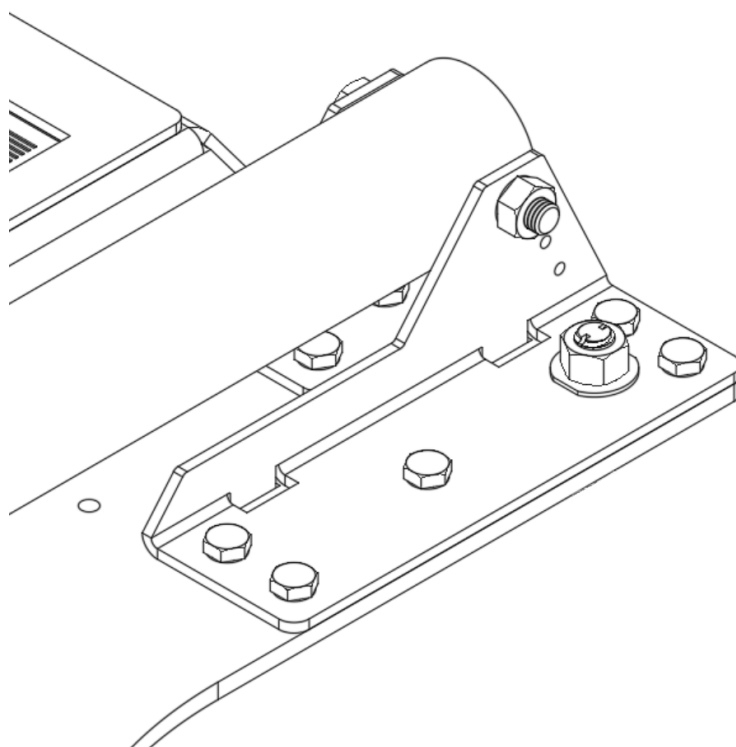

■ 5.6. Installing the power supply (only for constant power supply model)

Parklio constant power supply uses a AC/DC low output voltage supply to power the barrier. The power supply is powered from the electric line and the supply output is fed to the barrier.

The power supply replaces the battery pack. The battery pack and power supply cannot be used at the same time.

Maximum cable length is 25 m. Use 1.5 mm cross-section cable for power delivery to the barrier.

Each barrier must be fed by its own power supply and by a separate cable. One supply cannot be used for multiple barriers.

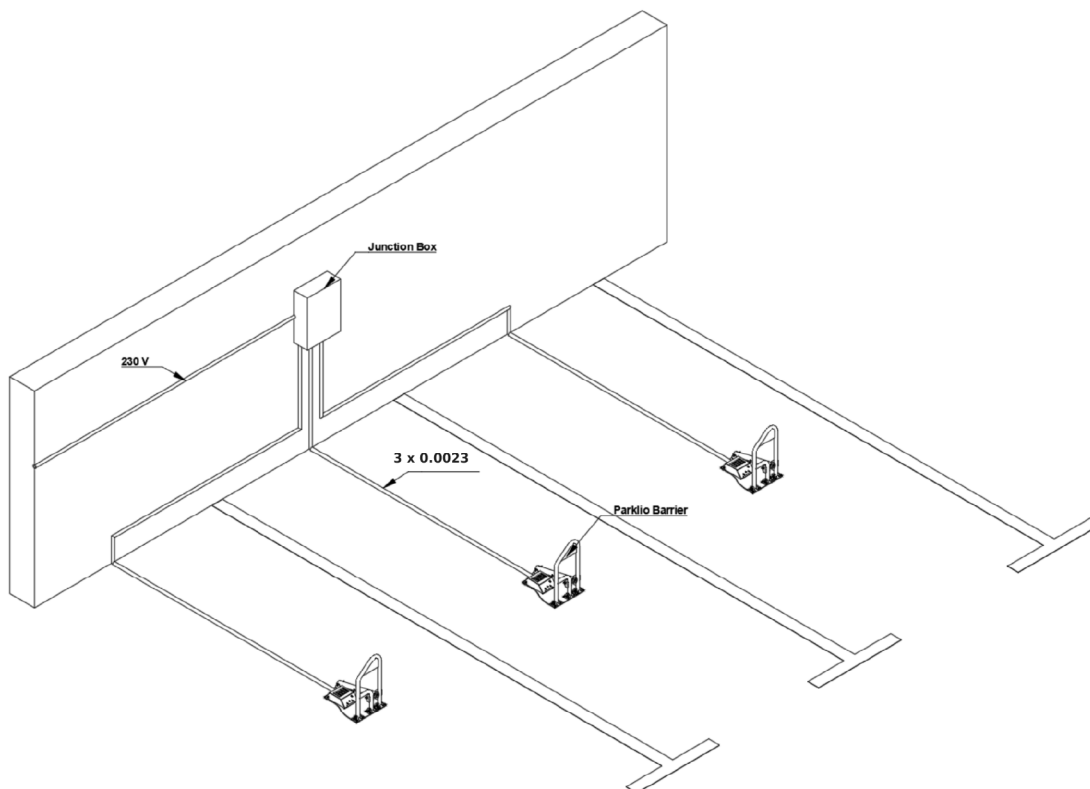

The illustration above is only an example for installing the barrier with constant supply. The final used setup is dependent on the environment. Disconnect all power while installing the barrier.

The power supply must be fed by a 230 V / 50 Hz or 120 V / 60 Hz electric line, protected by a differential magnetothermal switch complying with the law provisions in force. Connect the electric line wires to terminals L and N on the power supply. Connect the power supply + and - terminals to the cable leading to the barriers.

STEP 1. Bring the necessary infrastructure to the barrier. Feed the supply cable through the barrier base.

STEP 2. The barrier is provided with an adapter cable for connecting it to the constant supply. Disassemble the adapter.



STEP 3. Insert the power cable and connect it as shown. **The supply is polarity sensitive, use caution when connecting the cable to the power supply and connector.** Maintain the same polarity on the connector and the power supply.

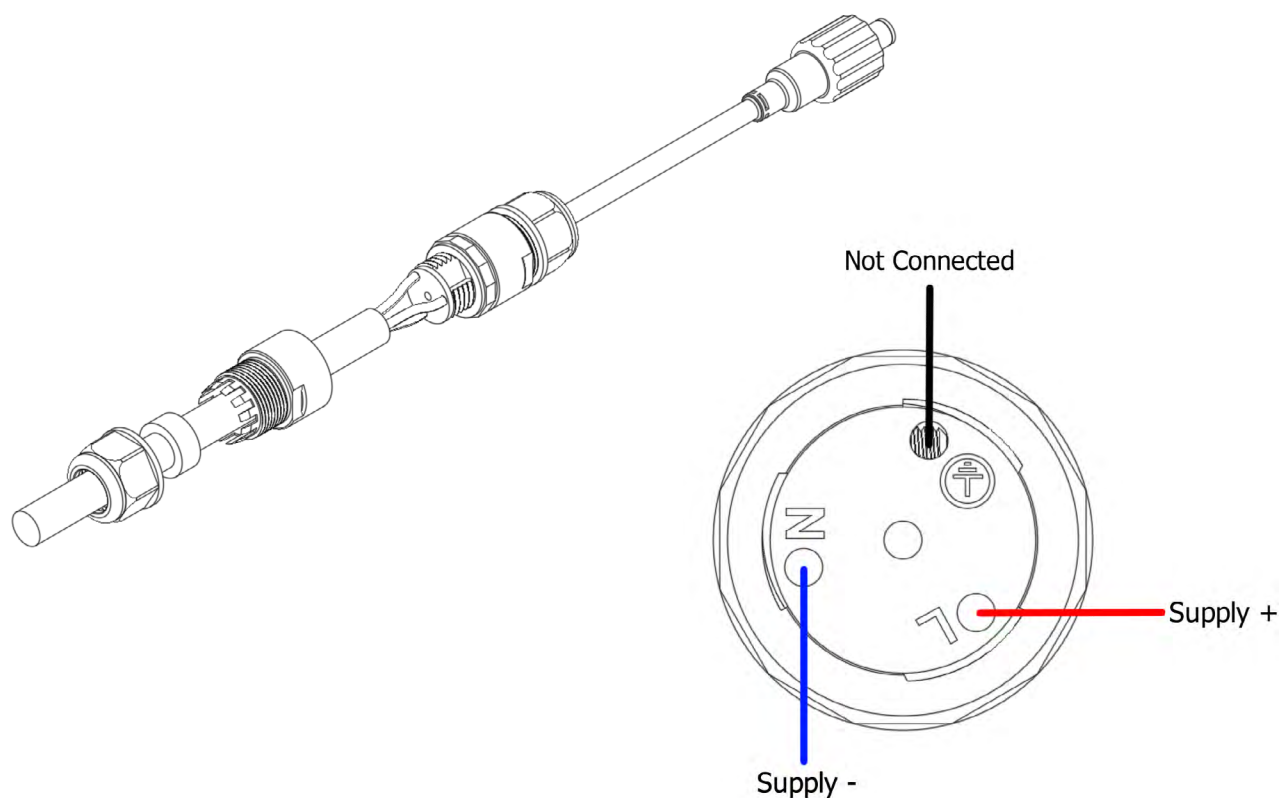

STEP 4. Assemble the connector.

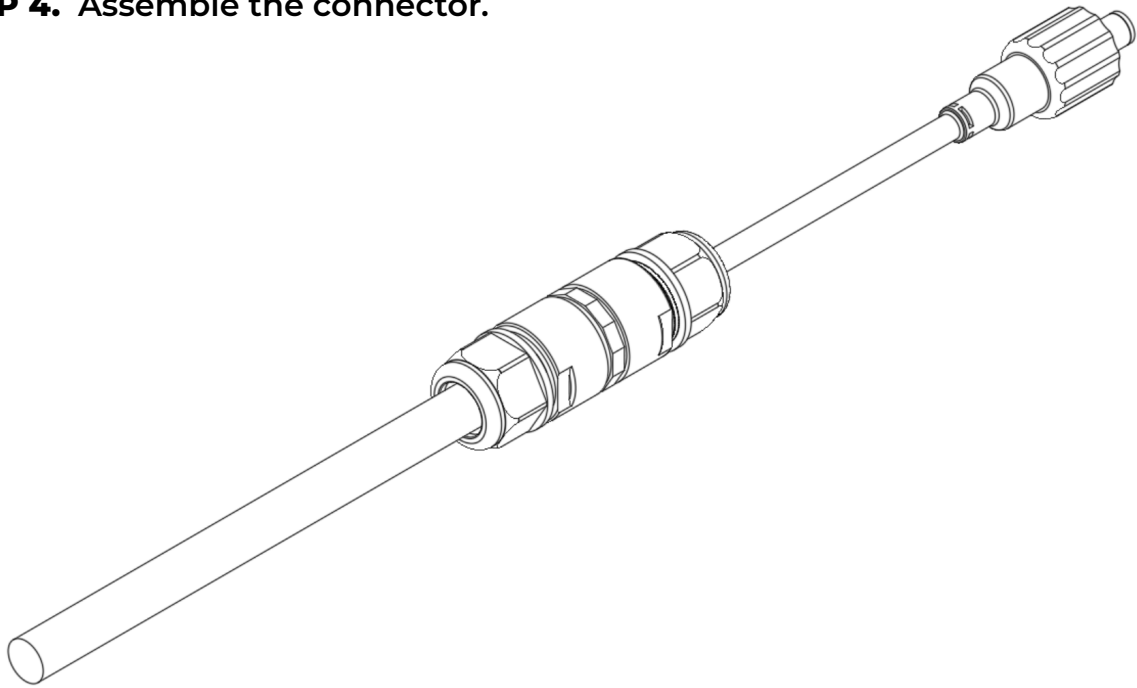

STEP 5. Connect the power supply to the cable running to the barrier.

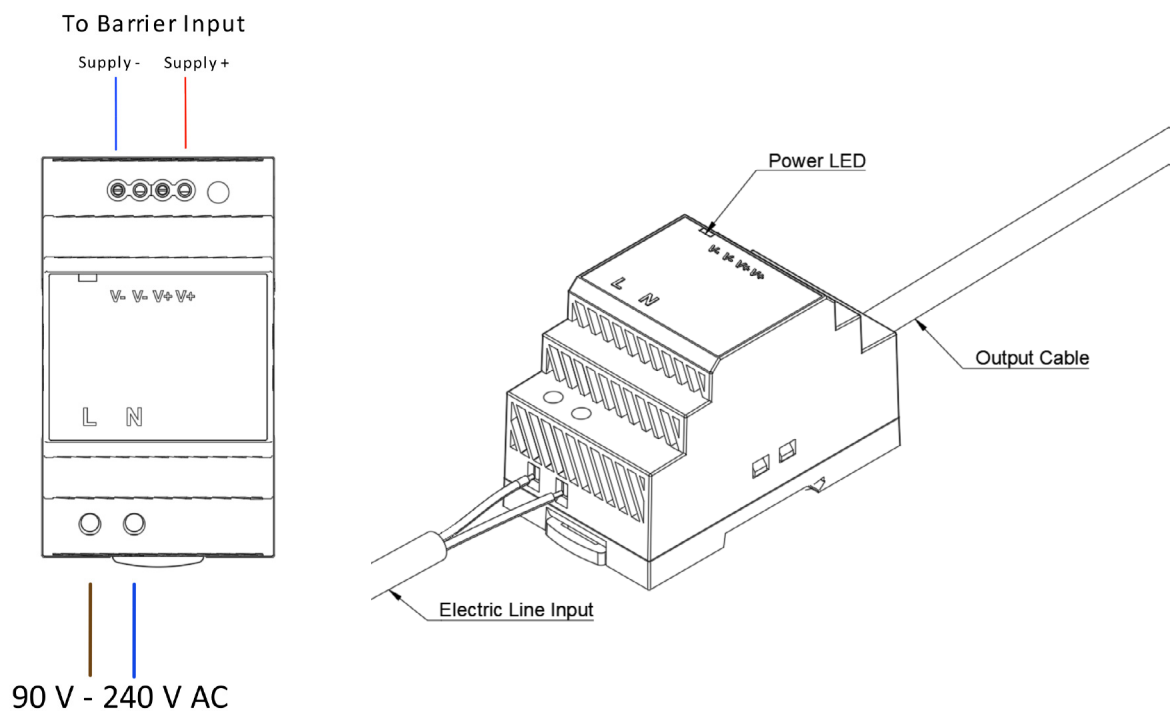

STEP 6. Connect the power supply to the electric line.

Disconnect all power while installing the barrier power supply. Make sure the electric installation is adequately protected and installed according to the laws in force.

STEP 7. Turn on the power. The LED on the power supply should power on indicating that the supply is functioning.

STEP 8. Connect the power supply jack in the barrier.

■ 5.7. Inserting the battery

To install the battery pack align the Parklio Battery Pack with the Control Unit and attach to the barrier base using the velcro joint on the bottom of the battery pack and on the barrier.

Take caution to plug the charging port input to prevent water ingress.

■ 5.8. Connecting the power

STEP 1. Plug in the power supply jack to the control unit input.

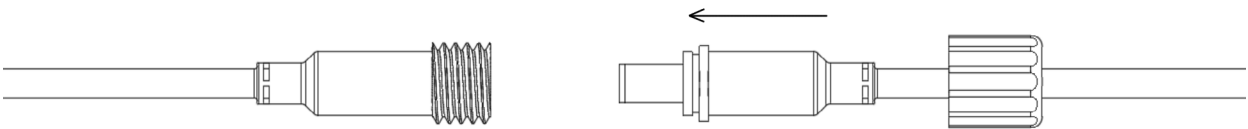

STEP 2. Position and tighten the cap.

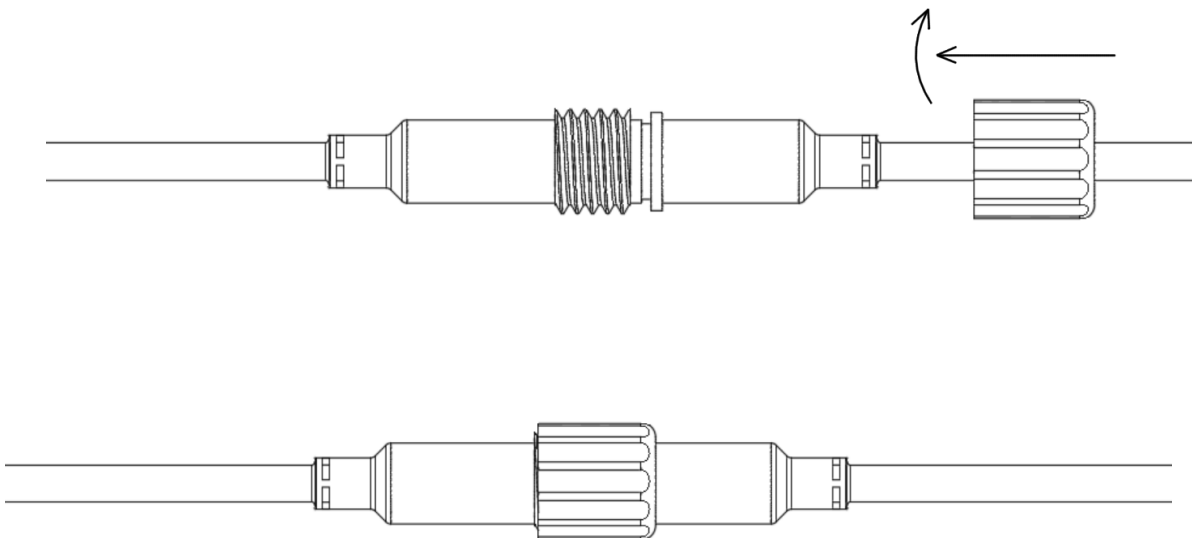

■ 5.9. Final steps

After connecting the power supply, perform the initial setup of the barrier through the mobile application as described in this manual. Lower the barrier cover and lock it. The barrier is ready for use.

6. Controlling the barrier

This section will provide detailed instructions on how to connect the mobile application with the barrier and how to control the barrier using the free Parklio Connect mobile application.



Please note that internet connectivity is required for the barrier's first connection and setup.

6.1. Installing the application

The application can be downloaded by scanning the following QR codes:

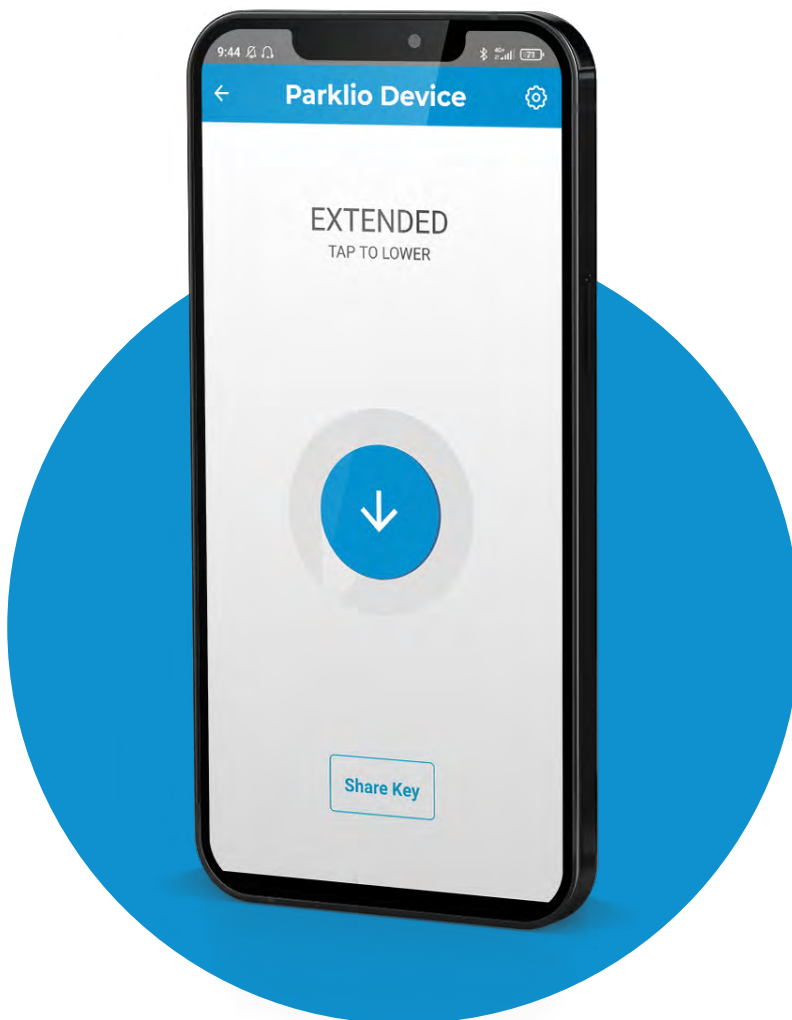

Android



iOS



Huawei



Or on the following links:

Android - <http://bit.ly/2iMkIn5>

iOS - <https://apple.co/2iaV7aA>

Huawei - <https://urldre.cloud.huawei.com/mCe8Pn0uD6>

■ 6.2. Register and login

To use Parklio Connect the user needs to be logged in. An user may login with an existing Google account, an Apple account, or the user may create and use a Parklio account with their email.

EMAIL
Enter Email

PASSWORD
Enter Password

Login

Sign up Forgot password?

OR

Sign in with Google

By clicking Login or Signup indicates you agree with our [Terms and Privacy Policy](#)

Parklio™ © 2021

Create an Account

EMAIL

PASSWORD

CONFIRM PASSWORD

Sign up

By clicking Login or Signup indicates you agree with our [Terms and Privacy Policy](#)

Parklio™ © 2021

To login via Google simply press the *Sign in with Google* button.

To login via Apple account simply press the *Sign in with Apple ID* button.

If the user has an existing Parklio account enter your email and password associated with the account into the corresponding fields and press *Login*.

In case a Parklio account has not been created previously press the *Sign Up* button which will open a new screen. There the user may input his email and password to create an account. After an account has been created the user may use his credentials to login into the application.

■ 6.3. Adding the barrier to your account

After logging in the dashboard containing all your parklio devices will be displayed.

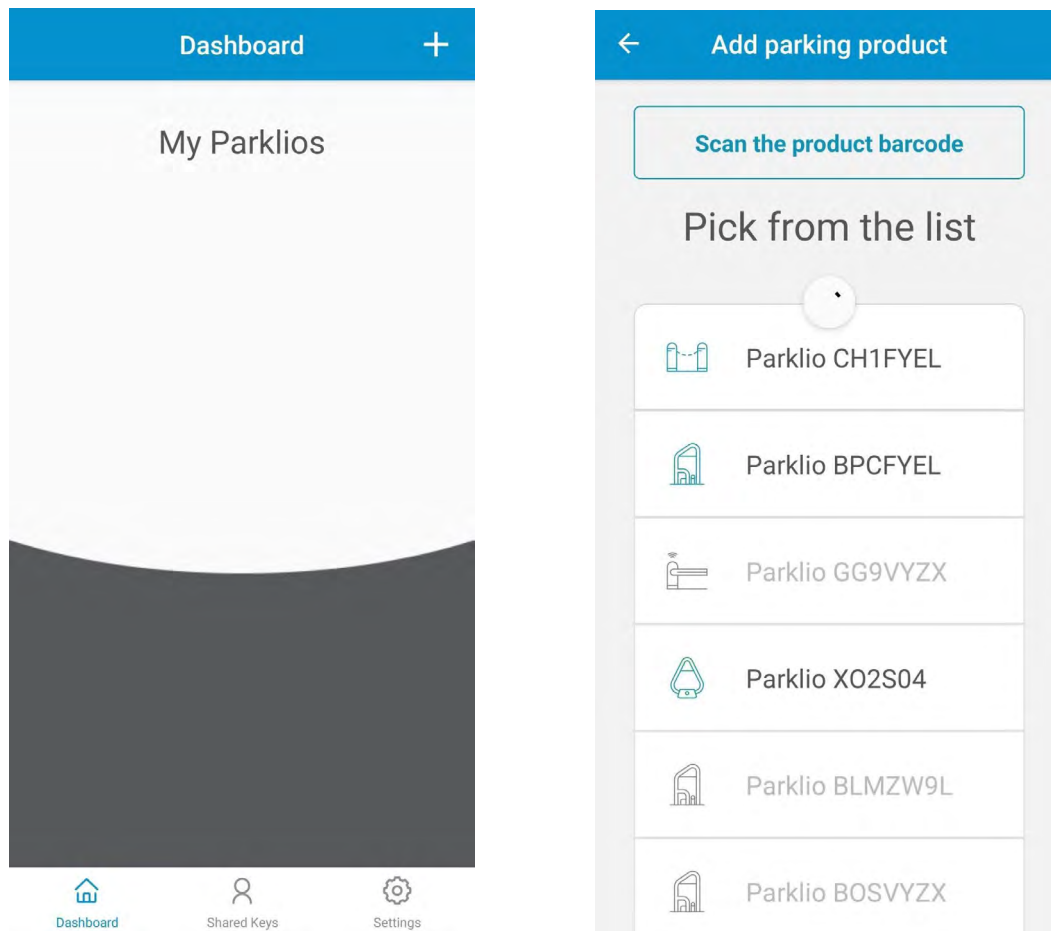

To add a barrier to the account press the + button on the top right corner of the dashboard. The Add parking product screen opens and the smartphone starts scanning for nearby Parklio devices. This step should be done in close proximity to the Parklio device you are adding.

Grayed out devices represent Parklio devices that are already set up. When the scanning is complete select the device you wish to add from the list of available devices. The device will be set up automatically and added to the users account.

In the above example screenshot by clicking on *Parklio BPCFYEL* the application starts the process of setting the barrier up. The process is automatic and the user is notified at the end.

■ 6.4. Connecting to the barrier

To be able to operate the barrier, view the state and change the barrier settings it is necessary to connect to the barrier.

This is done by going to the Dashboard and clicking on the barrier to connect to.

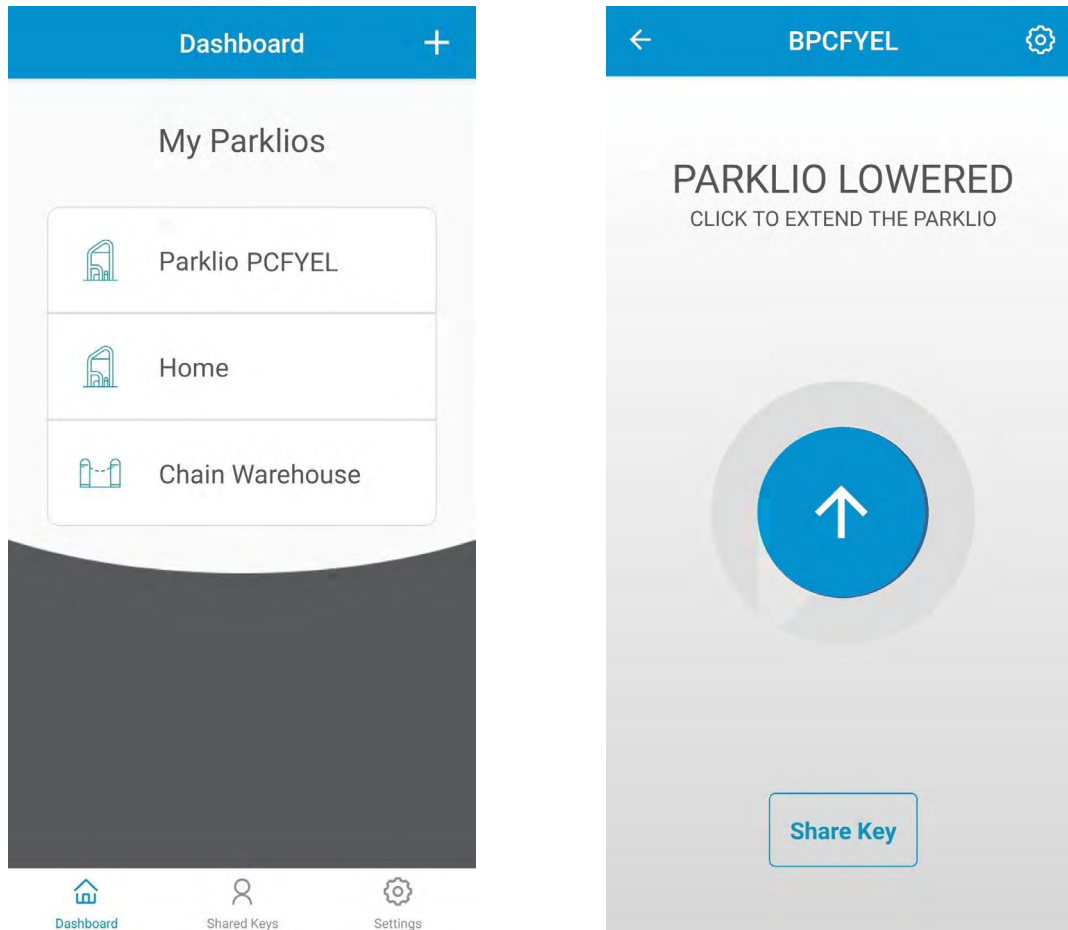

After a successful connect the screen will show the barrier status:

- **PARKLIO LOWERED** - Indicates the barrier is down (open)
- **PARKLIO EXTENDED** - Indicates the barrier is up (closed)
- **PARKLIO EXTENDING** - Indicates the barrier is moving up (closing)
- **PARKLIO LOWERING** - Indicates the barrier is moving down (opening)
- **CAR ON TOP** - The barrier is lowered and there is a vehicle above the barrier
- **BARRIER JAMMED** - The barrier jammed while moving up or down, check for any obstructions
- **AUTHENTICATION FAILED** - There was an error with communication to the barrier or with the barrier digital key, the key was probably reset

■ 6.5. Opening and closing the barrier

Opening and closing of the barrier is possible only when the user is connected to the barrier and while the barrier is in the EXTENDED or LOWERED state.

By clicking the button in the center of the main screen the barrier will lower or extend.

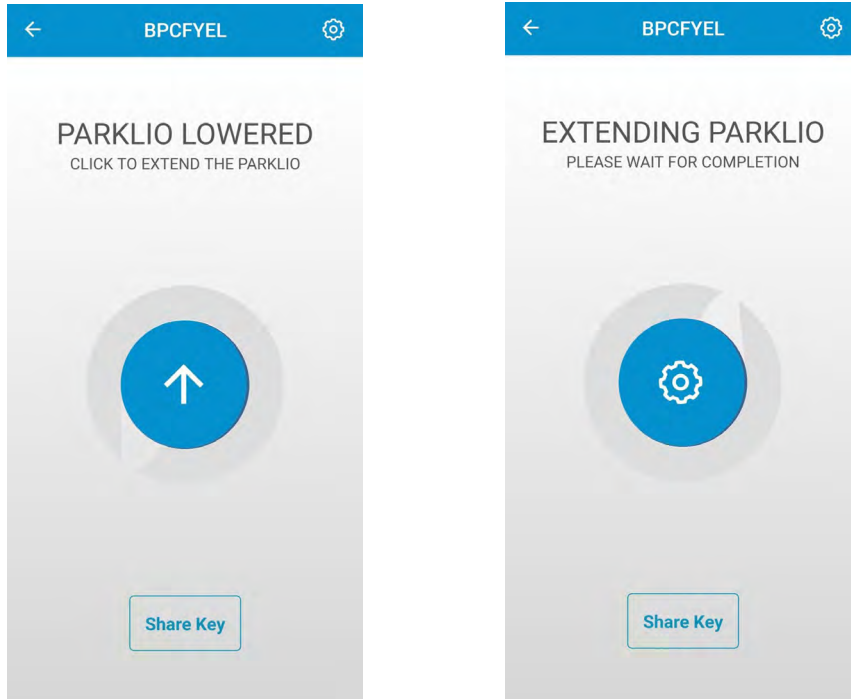

If the barrier detects that the vehicle is parked too close to or above the barrier, the message **CAR ON TOP** will be displayed. In this case, it is possible to raise the barrier by clicking on the car icon and pressing **FORCED WORK** in the dialog box. Only the administrator/owner of the barrier can do this.

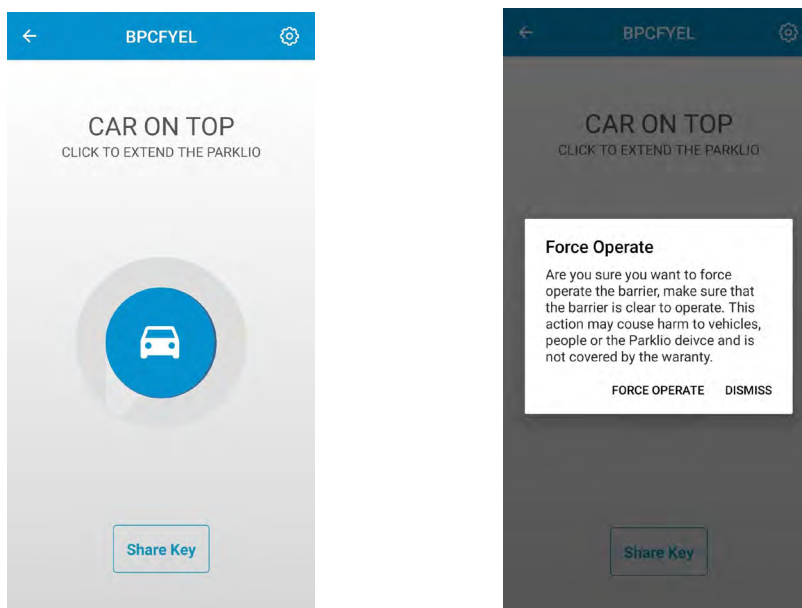

The barrier will ignore all obstacles, make sure the barrier path is clean before clicking *FORCE OPERATE*.

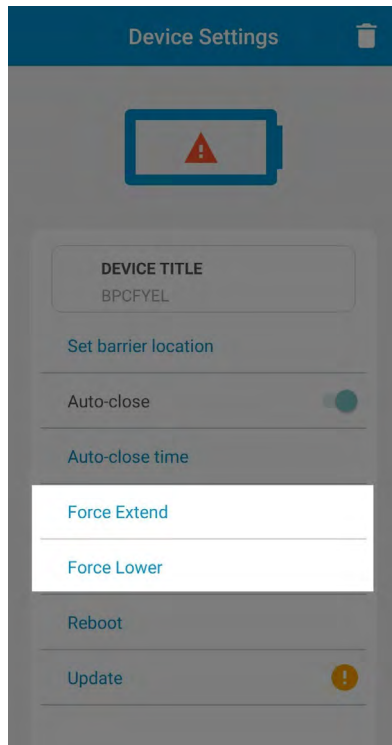

It is also possible to use Force Lower and Force Extend from the Device Settings menu.

■ 6.6. Barrier settings and information

Clicking the gear icon in the top right of the barrier screen will bring up the barrier settings. In the settings screen it is possible to view battery status, device information like the firmware version and ID, set the auto/close option and use the force extend and lower options.

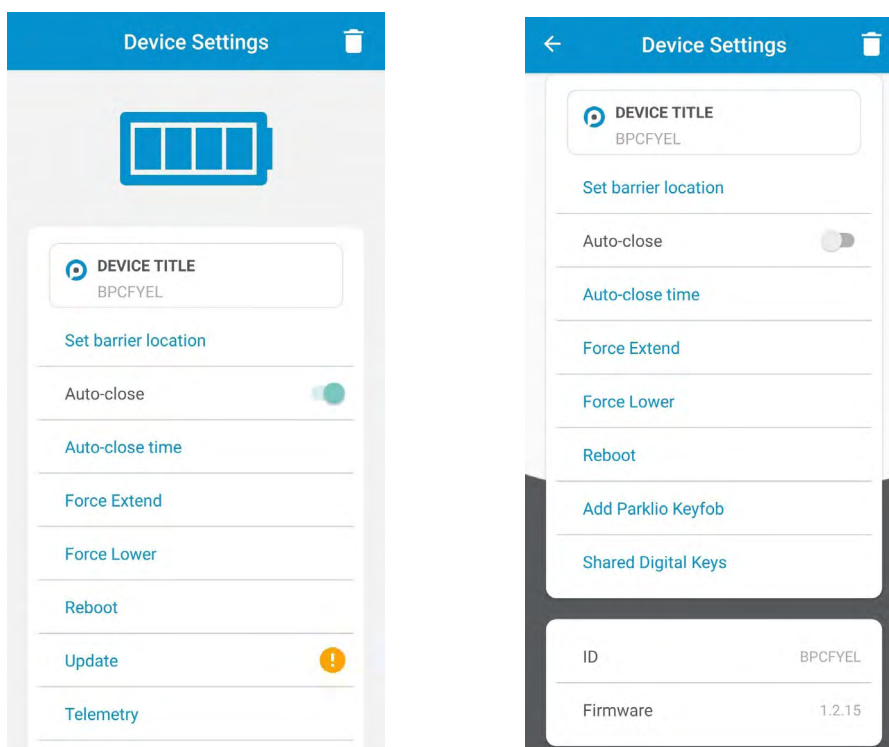

Change the device name

Parklio devices allow the user to change their name, so they can be more easily identified. To change the device name click on the *DEVICE TITLE* in the settings. Change the name of the device and click *SAVE*. The new name will now be displayed.

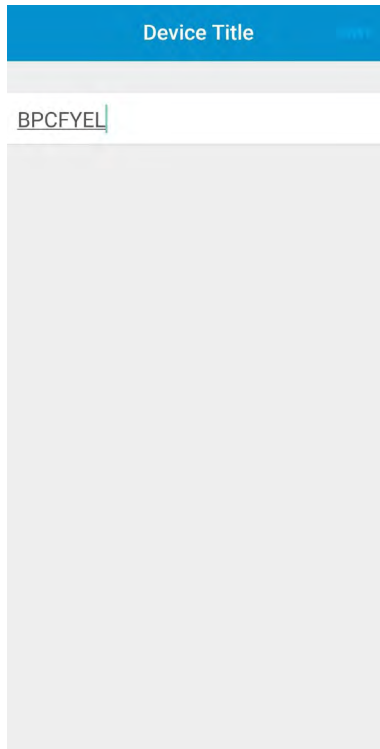

Change auto-close settings

To enable barrier auto-close toggle the auto-close button. A warning message will be displayed. To change the auto-close interval press the *Auto-close Time* button. The user may choose an auto-close time interval from 5 s to 120 s.

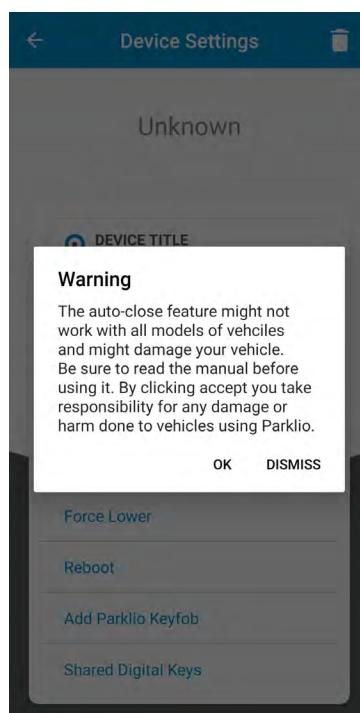

Key sharing

An important feature of all Parklio products is the option for key sharing. The application allows the owner of the device to share the digital key of his device.

To use this feature an internet connection is required. It is not required to be connected to a barrier via bluetooth.

All keys have a validity period, the key becomes active at the start date and is valid until the end date. A key may be shared to multiple users and multiple keys may be sent to one user.

In order to share a key press the Share Key button on the main barrier screen.

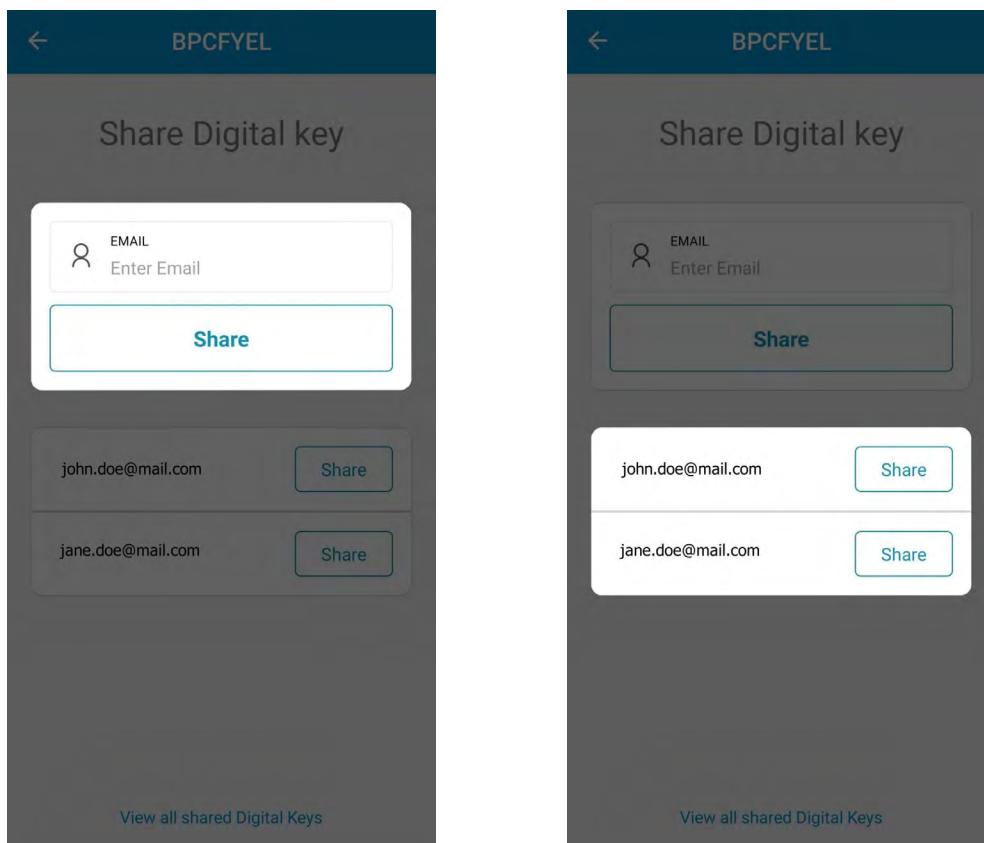

The first step is to enter the email of the user to whom the key will be shared or to choose from the list of previously shared users.

Next, it is required to select the key *START TIME* and *END TIME* using the calendar. After the start and end time are set press the Share Key button and confirm.

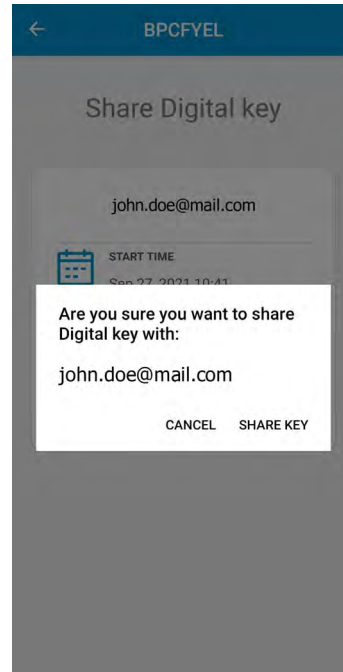

Blocking shared keys

If it is necessary to remove access from a user to whom a key was shared it is possible to do this from the Parklio Connect application.

To use this feature an internet connection is required. It is not required to be connected to a barrier via bluetooth.

In the *Device Settings > Share Digital Key* screen, press the *View all shared Digital Keys* at the bottom of the screen. All keys shared for the selected device are displayed. To block a certain user click on the *Block* button next to the user. Share keys can also be viewed from the *Device Settings* screen by clicking on *Shared Digital Keys*.

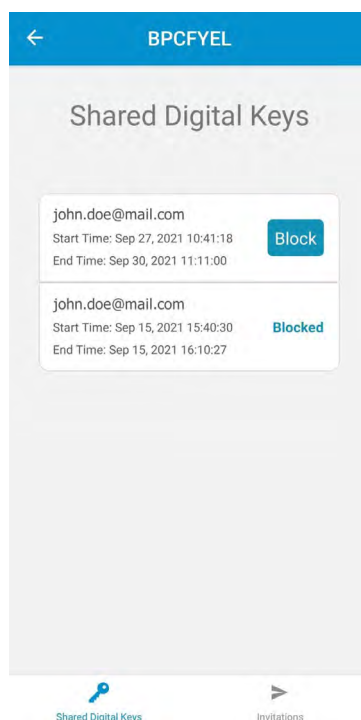

Updating the barrier

Parklio Smart Parking Barriers get feature improvements by using OTA (Over-The-Air) updates. These updates are carried out manually by the user. An orange icon near the update button in the barrier settings is shown if an update is available.

When updating the barrier make sure there is no vehicle located on top of the barrier. Please stay close to the barrier for the whole duration of the update.

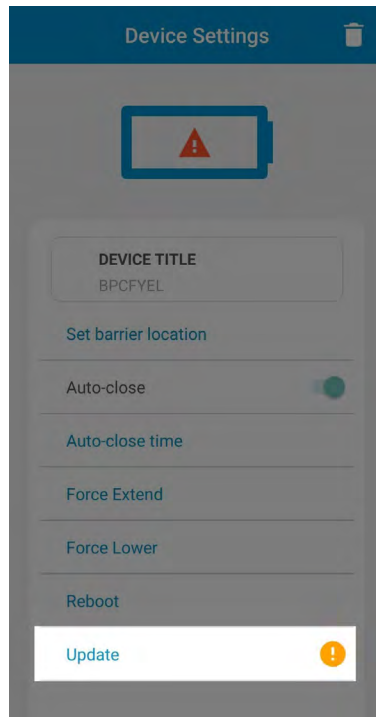

To update the barrier click the *Update* button in the *Device Settings* screen and press Start. Stay close to the device while the update is downloading.

Battery status

Barrier battery status is displayed in 5 levels with the battery icon at the top of the barrier settings. Each level corresponds to roughly 25% of battery charge.



If the battery is near empty a warning icon will appear. Please charge the battery.



Removing the barrier

In order to remove the barrier from your account or to delete a key which was shared to you enter the *Device Settings* screen and press the garbage can icon. A confirmation will pop up, press Yes.

When a device is deleted from your account all sent guest keys are still valid. They can only be invalidated by performing a barrier key reset or when the barrier is added to another account.

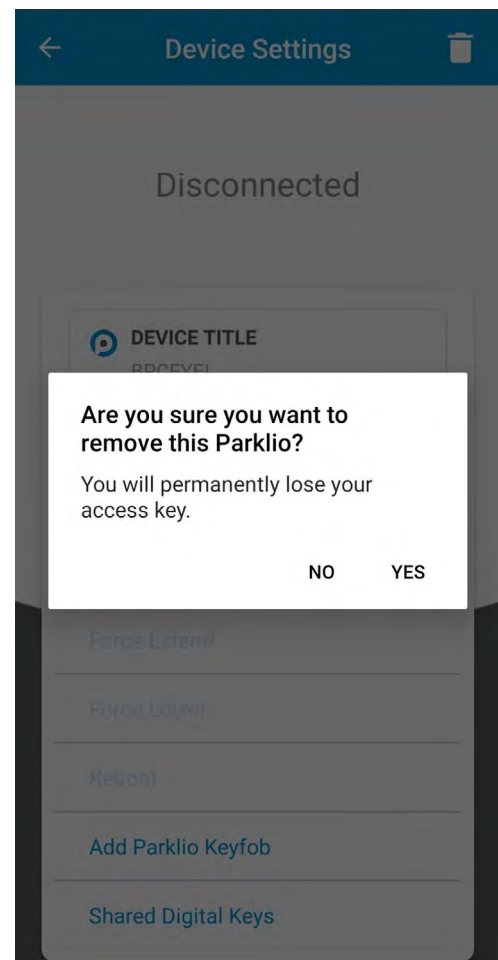
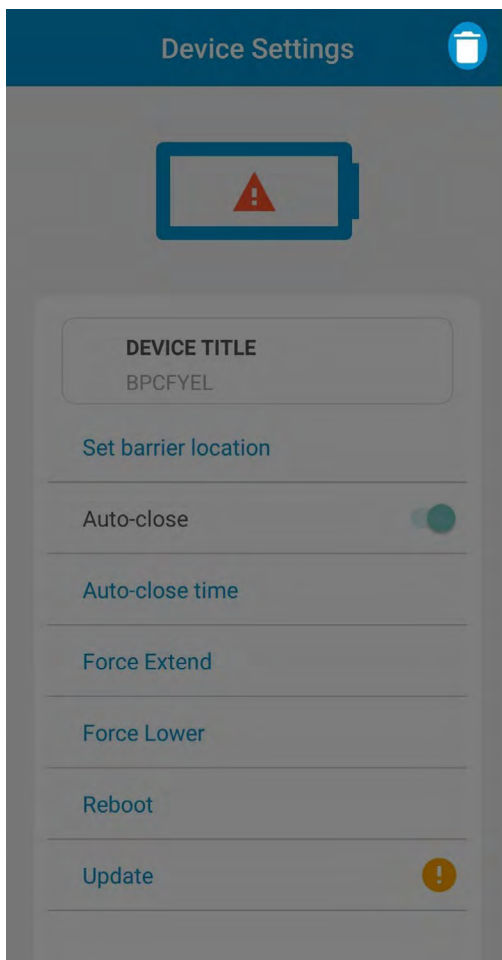

■ 6.7. Parklio Keyfob

An alternative to the free Parklio mobile application, there is the option to control Parklio products via a remote control device - Parklio Keyfob. The keyfob can be attached to the car interior or to a key chain. This way you can open the Parklio Barrier with a single press.

The use of the Keyfob still requires initial barrier setup via the Parklio Connect application. When the barrier is set up it is necessary to program the Keyfob from the Device Settings menu.

Direct Bluetooth connection with the barrier is not required for programming the Keyfob.

Open the Device Settings menu of the device you wish to control with the keyfob and press Add Parklio Keyfob.

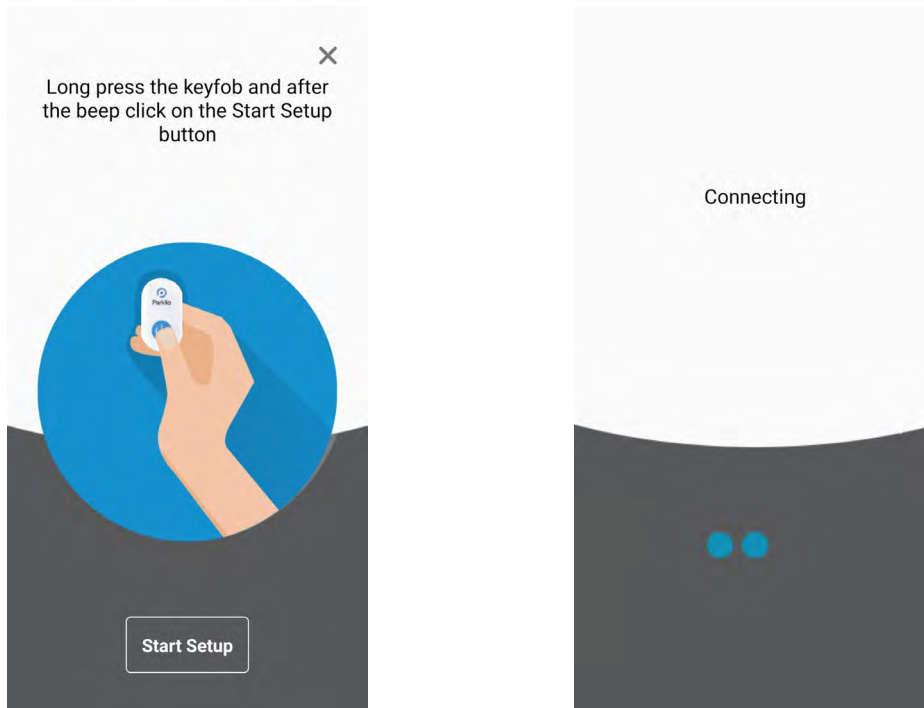

The first step when setting up the Keyfob is to put the Keyfob into the programming mode. This is done by pressing and holding the keyfob button for 3 seconds, until a long beep is emitted.

After the Keyfob is in the programming mode press Start Setup in the Add Parklio Keyfob screen. The application will indicate Connecting and Setting up the device. After a successful setup the Keyfob will emit two beeps.

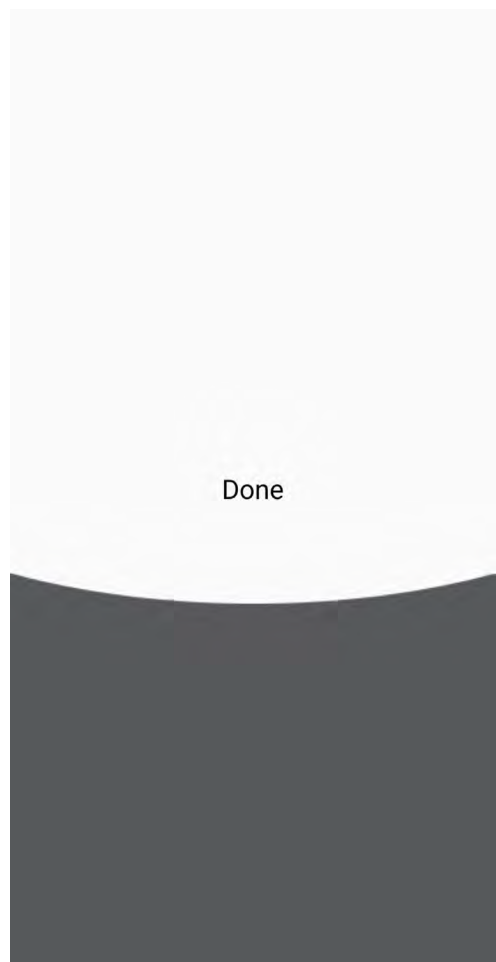
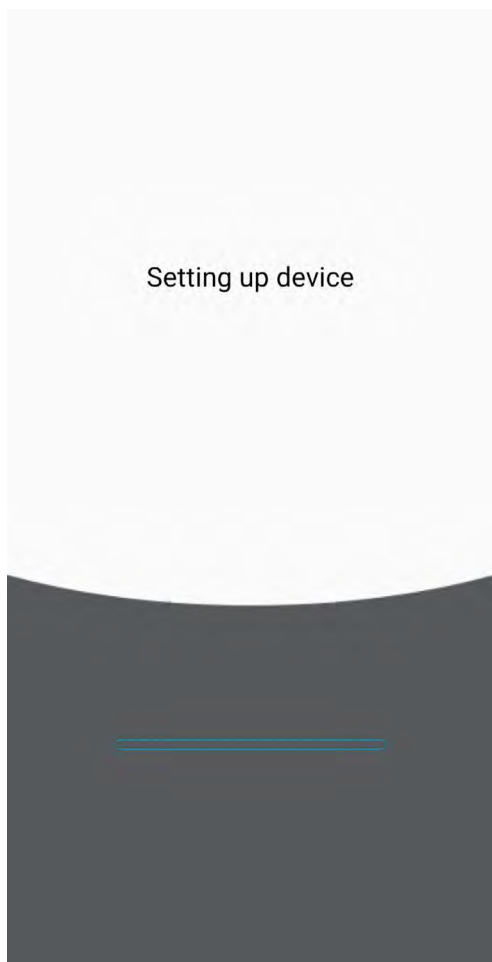

The keyfob can store only one device in its memory and it is controlled by pressing the keyfob button.

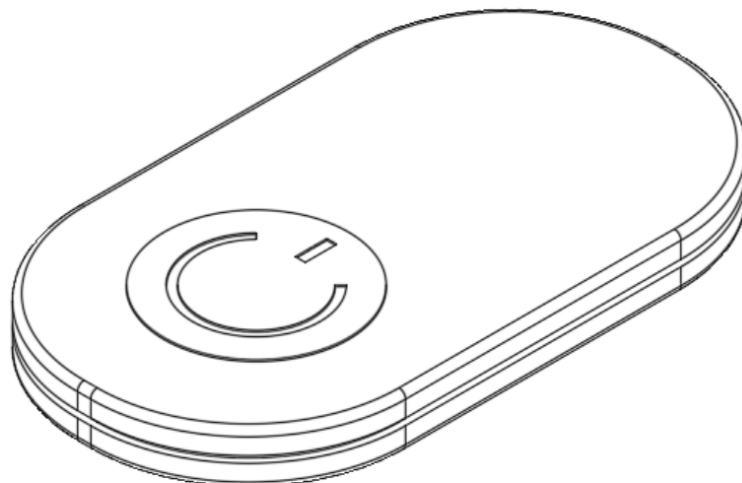

■ 6.8. Barrier key reset

The barrier digital key is set once the Barrier is added to a user account. This key can only be removed by resetting it. The reset is done by pressing and holding the Reset button for 3 seconds, until the green LED lights up.

When the barrier is in the reset state it can be added again to a user account via the Parklio Connect application.

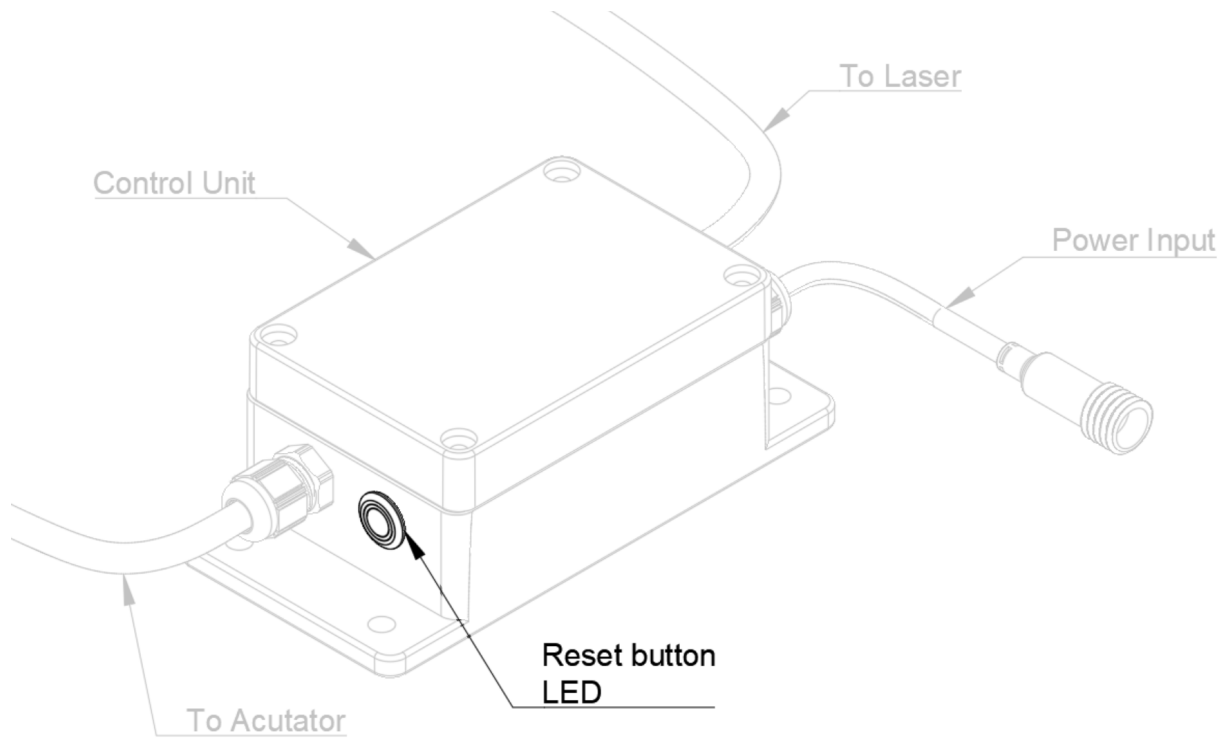

Resetting the barrier digital key will cause all the shared guest keys and the owner key to be unusable. It will be necessary to resend all guest keys individually.

7. Manual barrier control

To manually open the barrier, unlock the safety pin lock using the provided key, after that remove the safety pin while holding the barrier arm and actuator in place. Gently lower the actuator and the barrier arm.

To restore normal functionality just install the safety pin back.

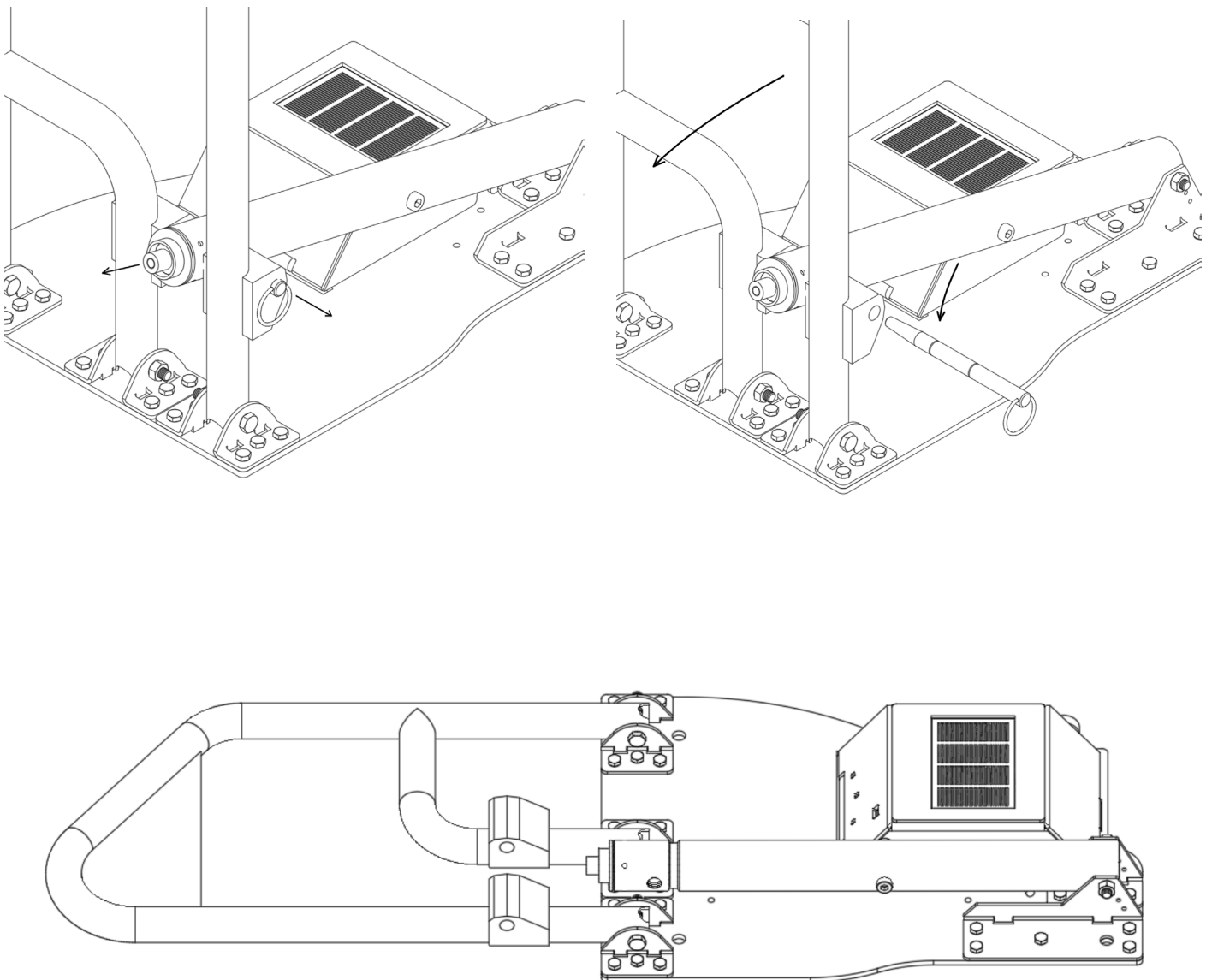

8. Cleaning and maintenance

Before taking any steps in cleaning and maintaining the device please disconnect the power supply.

Children should not clean nor maintain the barrier without proper supervision.

■ 8.1. Cleaning the laser sensor

Continued usage may cause dirt particles, mud, water stains and similar impurities to block the view of the laser sensor. This may lead to undesired behaviour.

To clean the laser sensor remove any obstructions by hand and clean the laser sensor glass cover with a clean cloth. You may use isopropyl cleaning alcohol (IPA) to clean the glass of any stains.

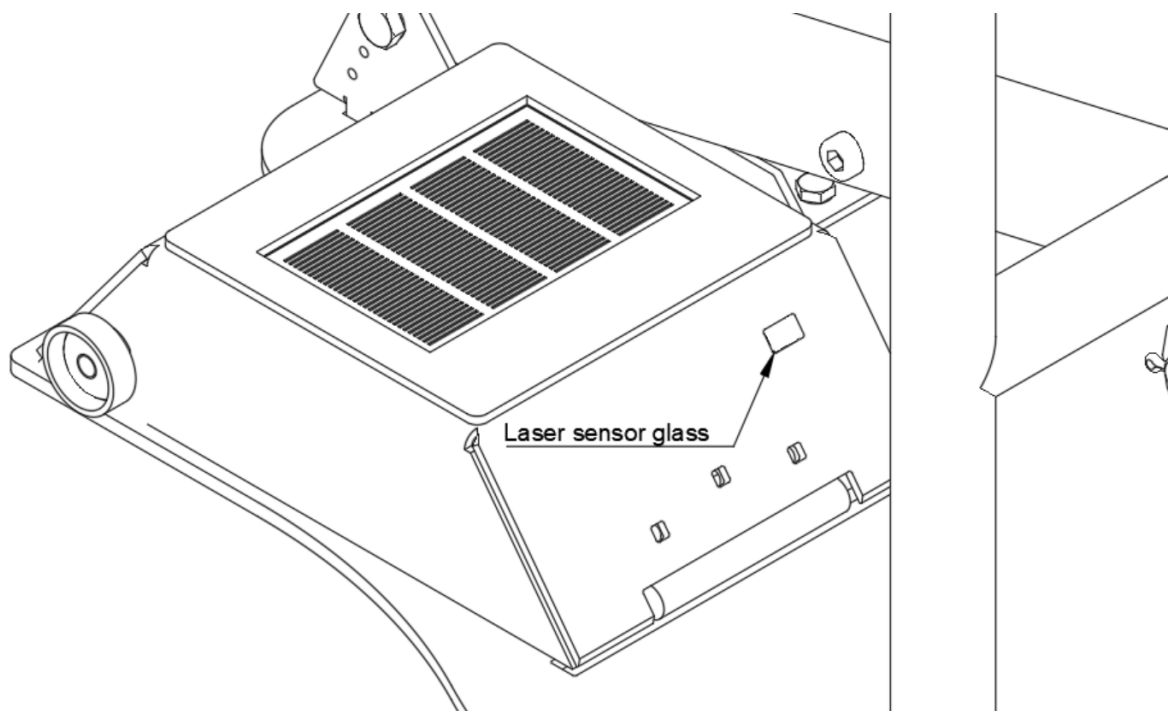

■ 8.2. Cleaning the inside of the barrier cover

The inside of the barrier cover should be only cleaned by a clean dry cloth and a dust brush.

■ 8.3. Cleaning the barrier exterior

The outside of the barrier may be cleaned with water, and in case of bigger stains with a detergent without abrasive properties.

Remove any obstacles around and from the barrier that may obstruct normal functioning, like clumps of leaves or branches.

■ 8.4. Replacing the safety pin

In case of excess force the Parklio Smart Parking Barrier has a safety pin to prevent damage to any other parts. The pin is designed to break into three parts.

In the case of a broken safety pin a replacement pin is needed for the barrier to operate correctly.

To replace the safety pin first unlock the safety pin lock, after that remove any broken pieces of the old safety pin. Insert the new safety pin as already described in the manual.

9. Disposal of the device

We use environmentally friendly materials for packaging that can be recycled, deposited or destroyed without any hazard to the environment. For this purpose, the packaging materials are appropriately labeled.

The symbol on the product or on its packaging signifies that this device should not be handled like ordinary household waste. Take this product to a suitable collection point for electrical and electronic equipment recycling.

Take out the worn battery from the barrier and dispose of it at a suitable place. The proper way of disposing of the barrier will help you to prevent possible negative consequences and impacts on the environment and human health that could occur in the event of improper disposal of the barrier. For more detailed information on disposing and processing the barrier, contact your local waste disposal service, utility company, or the store where you purchased the barrier.

10. FAQ

1. How do I reset the barriers digital key?

The barrier can be reset by holding the reset button on the control unit of the barrier for 5 seconds. The LED should turn on indicating a successful reset.

2. How do I charge the battery for powering the barrier?

Unlock the cover and open it. Remove the plug on the charging port and plug the supplied charger in. While the battery is charging the green LED light on the battery box will light up. When the battery is charged the green LED light will shut off. This is described in the Battery Pack section of the manual.

3. At what range can I use the barrier?

The barrier uses Bluetooth Low Energy to communicate with your smartphone. Typical range is 100 meters but in normal urban conditions it ranges around 30 m - 50 m.

4. I can't connect to the barrier? What should I do?

In case you can not connect to the barrier, and you have administrator privileges, reset the application and retry. If the error reoccurs, open the lid and reset the barrier via the „RESET“ button on the electronics box.

5. Do Parklio barriers have sensors?

Our barriers have a built-in set of sensors that detects if the car is parked above the barrier. In this way, it is impossible that the barrier closes if it senses an obstacle above. This sensor system consists of a laser sensor and a magnetometer and has a high accuracy of object presence detection.

6. What if the barrier is up and I don't have access to my mobile phone?

You can manually retract the barrier by removing the safety pin as instructed in this manual.

7. What do I do when the barrier is stuck?

If the application is telling you that a certain barrier is jammed you must remove all mechanical obstructions that are preventing regular function of the barrier. If you are sure that there are no obstructions check the battery. A low battery can cause the barrier to stop moving.

8. What do I do when the barrier does not close upon my departure?

Correct barrier positioning is crucial for correct automatic close behaviour. In case the barrier does not automatically close upon your departure first check if the „auto-close“ option in the settings of the application is turned on. If the problem persists contact customer support

9. Do I need to be connected to the internet to use the barrier?

To use the barrier you do not need either a mobile or WiFi connection. A mobile connection is needed only when initially setting up the barrier and when using shared keys.

10. Can two users operate the same barrier simultaneously?

A single user can operate only one barrier at a particular time. While a user is connected to the barrier, other users can not operate the same barrier

11. Does the app warn me when the battery levels are low?

The app will warn you if the battery levels are under 20% during connection to the barrier.

12. What do I do if an „Authentication key already set“ message appears during connection to the barrier?

to the barrier and has administrator privileges, you must reset the barrier to factory settings before pairing up your new phone to the barrier.

13. The application does not display any barriers when scanning?

Make sure that Bluetooth and Location permissions are enabled.

Declaration of Conformity

Declaration of Conformity

With regard to EMC, LVD and ERM Directives



Declare under our sole responsibility that the following product(s):

Parklio Smart Parking Barrier Model X

Fulfills the essential requirements of the EMC, LVD and ERM Directives

The following standards were applied:

EN 55016-2-3:2017
EN 61000-4-3:2006/A2:2010
EN 301 489-1 v2.1.1.(2017-02)
EN 60950-1:2006+A11:2009+A1:2010+A12:2011+A2:2013+AC:2015
EN 60950-22:2017
IEC 60950-1:2005+A1:2009+A2:2016, IEC 60950-22:2016

Authorized Signature

Address: Hercegovačka 78, 21000 Split, Croatia

Manufacturer: Amplifico d.o.o.

AMPLIFICO d.o.o.
za računalništvo i usluge
58117

I, the Manufacturer, hereby declare that the equipment as tested is representative within manufacturing tolerance limits